

phys. stat. sol. (b) 54, 565 (1972)

Subject classification: 10.2 and 13.4; 19; 20.3; 22.5.2

*Institut de Physique, Université de Neuchâtel, Switzerland***EPR Optical Detection of F Centre Pairs in Alkali Halides¹⁾²⁾****I. Pumping Cycle Kinetics and Characteristics of the Resonances**

By

Y. RUEDIN³⁾, P.-A. SCHNEGG, C. JACCARD, and M. A. AEGERTER

The electron paramagnetic resonance of F centres in the ground and excited states has been optically detected in the following alkali halide crystals: NaCl, KF, KCl, KBr, KI, RbBr, and RbI. A decrease of the radiative quantum efficiency of the F centre luminescence is observed when microwave transitions are induced between the spin levels. The mechanism responsible for this effect is an electronic tunnelling through the crystal field potential; the electron in the relaxed excited state of an F centre (\tilde{F}^*) is transferred non radiatively to another nearby F centre in its ground state (F_0), and leads to the momentary formation of an α and an F' centre. Such a process is a function of the total spin of the \tilde{F}^*-F_0 pair. The role played by the paired centres is confirmed by measurements at different F centre concentration. Moreover at high optical excitation pumping rate the population of the intermediate complexes ($F'-\alpha$) is large enough to allow an estimation of the rate of the reverse process $F' + \alpha \rightarrow F_0 + F_0$.

La résonance paramagnétique électronique des centres F dans l'état fondamental et l'état excité relaxé est détectée par une méthode optique dans sept halogénures alcalins: NaCl, KF, KCl, KBr, KI, RbBr et RbI. Les transitions hyperfréquence entre les sous-niveaux Zeeman induisent une diminution de la luminescence des centres F. Le mécanisme responsable de cette diminution est un processus de transfert électronique par effet tunnel à travers le potentiel cristallin entre un centre F dans l'état excité relaxé (\tilde{F}^*) et un centre F voisin dans l'état fondamental (F_0). Le complexe ainsi formé momentanément est composé d'un centre α et d'un centre F' . La probabilité d'un tel processus est fonction du spin total de la paire \tilde{F}^*-F_0 . La présence de centres appariés est confirmée par des mesures à différentes concentrations de centres F. D'autre part, pour une forte excitation lumineuse, la concentration des complexes intermédiaires ($F'-\alpha$) est suffisamment élevée pour estimer la probabilité du processus de retour $F' + \alpha \rightarrow F_0 + F_0$.

1. Introduction

The conventional methods used to detect the EPR in a ground or in a metastable state are not applicable for an excited state since the populations which can be attained are usually too small (short lifetime).

In some cases however it is possible to use optical methods which are not sensitive to the population but to the rate of optical pumping. Geschwind et al. [1] applied first such a method for the detection of the EPR in the $\bar{E}(^2E)$ state of Cr^{2+} in Al_2O_3 . They measured the intensity variations of the circularly polar-

¹⁾ Based upon the thesis submitted by Y. Ruedin at the Institut de Physique, Université de Neuchâtel (Switzerland) in partial fulfillment of the requirements for the "Docteur ès sciences" degree (1971).

²⁾ Work supported by the Swiss National Foundation for Scientific Research (FNSRS).

³⁾ Present address: Landis und Gyr AG, Zug (Switzerland).

ized components of the light emitted by this excited state, induced by changing the relative populations of the Zeeman sublevels by EPR.

Another optical method has been used by Mollenauer et al. [2] in the case of F centres in alkali halides. It consists in detecting the variations of circular dichroism of the F centres absorption band produced by EPR in the relaxed excited state.

In a previous paper by Jaccard et al. [3], a theory is presented concerning the quenching of the luminescence efficiency of F centres in alkali halides when the concentration increases. It also explains the variation of the luminescence quantum yield observed as a function of an applied magnetic field H , either at a low H -value $\left(\frac{g \mu_B H}{kT} < 1\right)$ or at a high H -value $\left(\frac{g \mu_B H}{kT} > 1\right)$. Measurements in the latter range have been performed in KCl by Porret and Lüty [4].

This theory is based on a mechanism proposed twenty years ago by Markham [5] and reviewed by Lüty [6], in which the electron of an F centre in its relaxed excited state may be transferred by a tunnel effect to a neighbouring F centre in its ground state. For close pairs this process is much more probable than the radiative decay. As a result, an anion vacancy (α centre) and an F' centre are created momentarily; this complex returns then to the ground state $F_0 + F_0$ by some non radiative process. The essential feature of this mechanism is that the attained F' state can only be a spin singlet [7]; thus, electron tunnelling will be possible only if the spins in F_0 and \tilde{F}^* states are antiparallel. If the spins are parallel the disexcitation shall proceed by the radiative process. This phenomenon induces a population difference between the parallel and antiparallel spin states of the F centre pairs so that microwave energy can be absorbed by the system if the resonance condition $\hbar\omega_0 = g \mu_B H_0$ is fulfilled. The effect being the conversion of pairs with parallel spins into pairs with antiparallel spins, a decrease of the total F centre luminescence will result. This provides a new way to detect optically the electron paramagnetic resonance either in the relaxed excited state or in the ground state of F centre pairs [8].

After a brief summary of the basic physical ideas used throughout these two reports (for more details see our previous paper [3]) the different transitions which can occur between the spin levels of an F centre pair are presented in Section 2; the next one deals with the experimental procedure (see also [8]). Finally the results concerning the g -factors, the halfwidths, the spectral dependence of the resonance peaks, as well as the effects of the F centre concentration and the optical excitation intensity on the EPR process are given and interpreted in Section 4. For these latter effects we exemplify the case of the KBr crystal, studied especially in great detail.

2. Transitions between the Spin Levels of the Pair

With the hypothesis of a random distribution of F centres in the crystal, it is found [3] that the luminescent quantum efficiency η follows the law: $\eta = \exp(-n V_t \langle P_t \rangle)$, where n is the instant concentration of F centres in the ground state and $V_t = (4/3) \pi R_t^3$ is a spherical critical volume defined by the maximum distance R_t between an \tilde{F}^* and an F_0 centre allowing the tunnel transfer with antiparallel spins. P_t is the tunnel probability for centre pairs such that $0 \leq P_t \leq 1$ for $R \leq R_t$ and $\langle P_t \rangle$ is the average of P_t taken on the spin levels and on the configurations of the (random) nuclear fields.

In the following discussion we assume that at resonance ($\hbar\omega_0 = g\mu_B H_0$), H_0 is high enough to decouple the possible spin-spin and hyperfine interactions of the pair electrons. Consequently a single axis of quantification exists along which both spins are good quantum numbers. This means that we have to deal with purely parallel or antiparallel spin states. This last assumption is not always fully encountered; it is the case for instance of the alkali iodides where hyperfine interactions are particularly large.

The energy levels of an F centre pair in the ground state (F_0-F_0) and in the relaxed excited state (\tilde{F}^*-F_0) are shown in Fig. 1a according to which we define the following populations:

$$\begin{aligned} N'_p &= N'_1 + N'_2 && \text{F centre pairs with parallel spins in state } F_0-F_0, \\ n_p &= n_1 + n_2 && \text{idem in state } \tilde{F}^*-F_0, \\ N'_a &= N'_3 + N'_4 && \text{F centre pairs with antiparallel spins in state } F_0-F_0, \\ n_a &= n_3 + n_4 && \text{idem in state } \tilde{F}^*-F_0, \\ n' &&& \text{F}' + \alpha \text{ complexes formed by electron tunnelling,} \\ N_i &&& \text{isolated F centres in ground state,} \\ n_i &&& \text{idem in excited state.} \end{aligned}$$

Neglecting the populations of the excited centres n_a, n_p, n_i we write

$$n_0 = N_i + 2(N'_a + N'_p) + 2n' = n + 2n',$$

where n_0 is the total concentration of F centres without pumping light and $n = N_i + 2(N'_a + N'_p)$ is the instant ground state concentration under irradiation. The Zeeman splitting is noted $\Delta E_e = g_e \mu_B H$ in the \tilde{F}^* state and $\Delta E_f = g_f \mu_B H$ in the F_0 state.

Since the observed spin-spin relaxation time in the ground state of the F centre is of the order of 10^{-6} s in KCl [9], a spin temperature $T_s \cong T_{\text{lattice}}$ describes the relative populations of the ground state. By lack of information concerning the other crystals we shall admit the same situation for all crystals presently studied.

Fig. 1b shows the optical transitions which can be induced from the ground state. It is easy to verify that $N'_p \approx N'_a$ for all temperatures such that $T_s \cong \cong 1.7^\circ\text{K}$ and $H \cong 4\text{ kG}$ ($g \approx 2$). From this, it follows that the loss of spin memory ε in a pumping cycle [2, 4, 10] does not play any role in our experiments; we shall put then $\varepsilon = 0$. The pumping rate is $2W_1$ for a pair.

Fig. 1. a) Energy levels of an F centre pair in ground state (F_0-F_0) and in relaxed excited state (\tilde{F}^*-F_0). N_K and n_K refers to the populations of the different Zeeman sublevels separated in energy respectively by $\Delta E_f = g_f \mu_B H$ and $\Delta E_e = g_e \mu_B H$. b) Optical transitions and pumping rate induced by light excitation in the F-band. W_I : excitation probability of an F centre; ε : spin-flip probability during the optical transition.

c) Transitions induced between the spin levels of an \tilde{F}^*-F_0 pair by a microwave EM field (index M) and the lattice phonons (index R). The filled arrows show the conversion of a pair with parallel spins into a pair with anti-parallel spins. The unfilled arrows show the inverse conversion.

d) Radiative (rate W_r) and non radiative tunneling (rate W_t) disexcitation processes considered here.

e) Non radiative tunneling process affecting the F' centre $F' + \alpha \rightarrow F_0 + F_0$ (rate W_{t1})

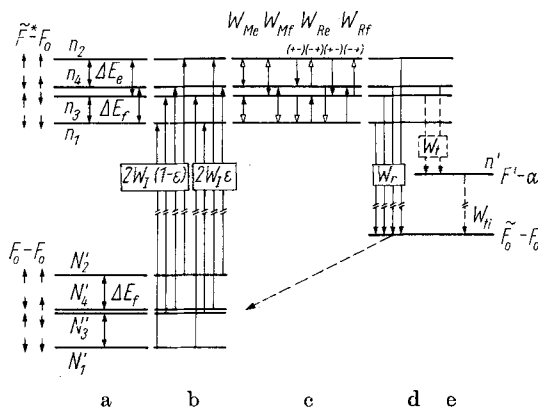

Fig. 1c shows the transitions induced between the spin levels of an $F_0\text{-}\tilde{F}^*$ pair by the three following interactions:

1. Interaction with a microwave electromagnetic field, where the rates are W_{Me} and W_{Mf} for transitions in the \tilde{F}^* and the F_0 centre, respectively.
2. Interaction with the lattice phonons (spin lattice relaxation), where

$$W_{Re,f}^- = W_{Re,f}^+ \exp\left(-\frac{\Delta E_{e,f}}{kT}\right).$$

In an $\tilde{F}^*\text{-}F_0$ pair, the spin lattice relaxation for the member in the ground state is slow compared to the radiative transition rate W_r of the other member.

Anticipating the results, we write $W_{Re}^+ \approx W_{Re}^- \approx W_R$; this simplification is valid for all crystals for $T \gtrsim 10^\circ\text{K}$; on the other hand, since W_R becomes much smaller than W_r when T is lower than 10°K the spin lattice relaxation is not effective below this temperature (see next report).

3. Spin-spin interaction between pairs and isolated centres. This process is not taken into account; we assume that it is slower than the radiative rate.

As already mentioned the disexcitation of the pairs proceeds by a radiative process (rate W_r) which in the case of antisymmetric spins is in competition with an electron tunnelling process (rate W_t) (Fig. 1d). W_{ti} is the return rate of $F' + \alpha$ complexes into the ground state $F_0\text{-}F_0$ possibly by an electron tunnel transfer too.

According to these considerations, Fig. 1 can be reduced to the block diagram of Fig. 2.

The mean relative tunnelling probability is then

$$\langle P_t \rangle = \frac{W_t n_a}{W_r (n_a + n_p) + W_t n_a}$$

and the concentration $2N$ of the F centre pairs ($N = N'_a \approx N'_p$) is given by the system

$$\frac{dn_p}{dt} = 2W_I N - (W_r + W_M + W_R) n_p + (W_M + W_R) n_a,$$

$$\frac{dn_a}{dt} = 2W_I N + (W_r + W_M) n_p - (W_r + W_M + W_R + W_t) n_a,$$

$$\frac{dn'}{dt} = W_t n_a - W_{ti} n'.$$

A fourth equation is obtained by writing that the total concentration of pairs and F' centres is constant ($2N_0 = (N'_a + N'_p + n')$ in the absence of the pumping light).

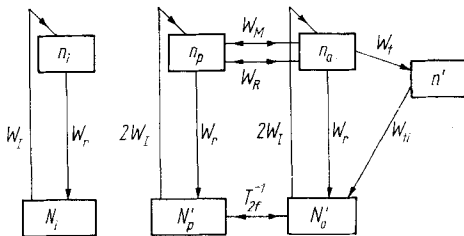

Fig. 2. Block diagram of the electronic and phononic transitions (W) for isolated and pairs of F centres. See text or Fig. 1 for explanation of symbols

The stationary solution of these equations gives

$$\langle P_t \rangle = \frac{W_t \left(\frac{1}{2} + \frac{W_M}{W_r} + \frac{W_R}{W_r} \right)}{1 + 2 \left(\frac{W_M}{W_r} + \frac{W_R}{W_r} \right) + W_t \left(1 + \frac{W_M}{W_r} + \frac{W_R}{W_r} \right)}$$

and

$$N \approx N_0 \frac{1}{1 + \frac{W_I}{W_{ti}}}$$

this last expression being calculated for the case where $W_R + W_M < W_r$.

The total number of photons emitted per second being $I_L = W_I \eta n V$ where V is a volume equal to the section of the light beam multiplied by the crystal thickness in which the optical transition rate W_I is assumed to be constant, we can evaluate the variation of the luminescence, ΔI_L , emitted by the F centres when microwaves are switched on:

$$\frac{\Delta I_L}{I_L} = \frac{\Delta \eta}{\eta} + \frac{\Delta n}{n}.$$

In [3] we show that the relative variation of the quantum yield is given by

$$\frac{\Delta \eta}{\eta} = 1 - \exp \{ -n V_t [\langle P_t \rangle (W_M \neq 0) - \langle P_t \rangle (W_M = 0)] \}.$$

Assuming that the exponent is smaller than unity, we can write in first approximation

$$\frac{\Delta \eta}{\eta} \approx n V_t \Delta P_t.$$

The second term in ΔI_L being negligible in not too heavily doped crystals ($\approx 5 \times 10^{17} \text{ cm}^{-3}$) we write

$$\Delta I_L = -W_I \eta_{(W_M=0)} \Delta P_t V V_t n^2.$$

We note that in this limit $n^2 V_t$ is just the concentration of the paired F centres so that

$$\Delta I_L = -4 N_0 V \eta_{(W_M=0)} \Delta P_t \frac{W_I}{1 + \frac{W_I}{W_{ti}}}.$$

It is interesting to see at this point that the quantum efficiency may increase to unity when W_I/W_{ti} becomes much greater than 1: this means that all the pairs would be converted into F' centres, which in this model do not absorb F light.

Finally, the quantum efficiency can be written

$$\begin{aligned} \eta &= \exp(-n V_t \langle P_t \rangle) \\ &= \exp \left[-\frac{4 N_0}{n} \left(\frac{1}{1 + \frac{W_I}{W_{ti}}} \right) \langle P_t \rangle \right]. \end{aligned}$$

3. Experimental Procedure

The alkali halide crystals purchased from Korth (Kiel, BRD) ("Ultra pure" grade) were cleaved at the approximative dimensions $5 \times 5 \times 2$ mm³ and placed on their edge on the bottom of a cylindric microwave cavity. This cavity is machined from a copper block and is provided with two coaxial holes on both sides of the crystal which allow optical excitation and detection as well as creation of F centres by X-rays irradiation. For that a Mueller 150 Be tube with a W anticathode was operated at 150 kV, 9 mA. The radiation was usually filtered by 0.5 mm Al and 3.5 mm SiO₂ (cryostat windows). The crystals were irradiated at $100^\circ\text{K} < T < 200^\circ\text{K}$ for 30 to 120 min. In this way, the centres were homogeneously distributed in NaCl, KF, and KCl but not in KBr, KI, RbBr, and RbI. The cavity was held at a constant temperature between 1.7 and 300 °K in a liquid helium cryostat (Andonian, MHD-3L-30N/0.7M-H). A block diagram of the spectrometer is given in Fig. 3. The X-band microwave generator (Varian X13 reflex klystron) is followed by a slide screw impedance adapter and by an uniline in order to obtain the maximum power from the klystron. Two directional couplers inserted in the circuit provide a means of control. The first one (on the right of Fig. 3), extracts a known fraction of the incident power which is measured by means of a thermistor coupled to a watt-meter (HP 430 CR). The second one controls the matching and the tuning of the cavity (critically coupled).

The microwave field in the cavity is chopped by means of a square voltage superimposed to the tension of the klystron reflector, thereby reducing periodically the energy in the cavity by a factor of 25 at least.

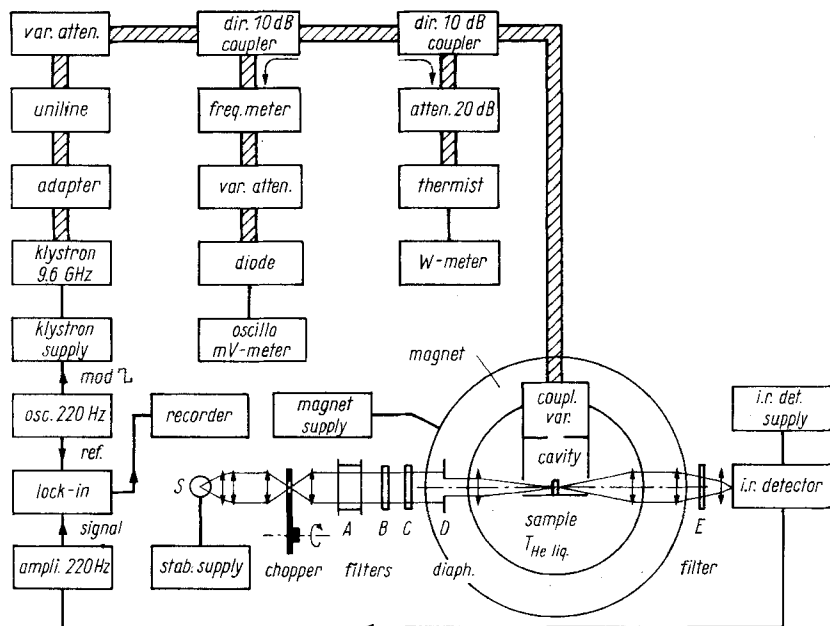

Fig. 3. Block diagram of the EPR spectrometer designed for optical excitation and detection

F centres are usually excited in the F and K absorption bands. The optical excitation device consists either in a QI 150 W lamp (Philips 7158) or a mercury high pressure one (Osram HBO 200). The light is filtered by 2 broad band filters: A (CuSO₄ solution of variable concentration), B (Balzers Calflex B₁K₁, anticalorific). The filter C (Wratten 22) was introduced in order to verify, for KBr, that the results are independent of the excitation spectrum.

The chopper and the diaphragm D are only used to optimize and to control the incident and the luminescence light flux.

The F centre luminescence is detected either with a PbS photoresistance (Mullard 119 CPY), or in some cases with a photomultiplier (Philips XP 1005). The filter E (Schott RG 715 for NaCl, KF, KCl and Wratten 87 for KBr, KI, RbBr, RbI) is placed in front of the detector in order to eliminate completely the excitation light.

The output signal from the detector, modulated at the chopping frequency of the microwaves, is amplified by a selective amplifier (P.A.R. 110), followed by a lock-in amplifier (P.A.R. JB5) and then recorded (HP 7128 A).

4. Results and Interpretation

4.1 *g*-factors and halfwidths

We have studied eight alkali halides crystals: NaF, NaCl, KF, KCl, KBr, KI, RbBr, and RbI. Among these, NaF is the only one for which no signal was detected. This is probably connected with the non radiative disexcitation characterized by a low activation energy and observed in this crystal by Podini [11]. In all other cases we observe gaussian resonant peaks more or less resolved. Three examples of the resonant spectra are given in Fig. 4, 5, 6. The dotted lines are the results of a numerical decomposition of the resonance spectra in two gaussian peaks achieved by using the MINDEF program developed by Beiner [12]. Let us note that all the samples were oriented with the [100] direction parallel to the magnetic field. However the angular dependence of the signals was checked for KBr, but no measurable variation could be detected.

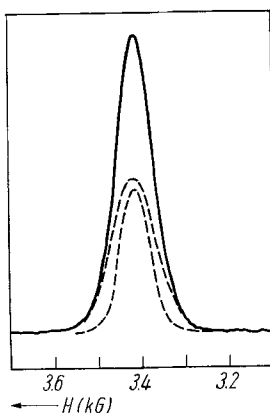

Fig. 4. Optically detected EPR signal in KF at $T = 16.5$ °K; $\nu = 9.541$ GHz, full line: signal as recorded, dotted line: best fit with two gaussian peaks (see text)

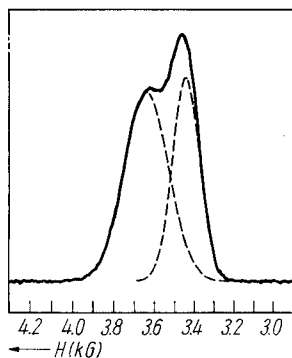

Fig. 5. Optically detected EPR signal in KBr at $T = 15.9$ °K; $\nu = 9.571$ GHz, full line: signal as recorded, dotted line: best fit with two gaussian peaks (see text)

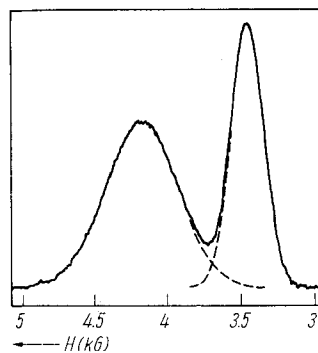

Fig. 6. Optically detected EPR signal in KI at $T = 9.7$ °K; $\nu = 9.562$ GHz, full line: signal as recorded, dotted line: best fit with two gaussian peaks (see text)

Table 1

crystal	ground state				relaxed excited state			
	present data *)		Seidel and Wolf [9]		present data *)		Mollenauer [2, 13]**)	
	<i>g</i>	$\Delta H_{1/2}$ (G)	<i>g</i>	$\Delta H_{1/2}$ (G)	<i>g</i>	$\Delta H_{1/2}$ (G)	<i>g</i>	$\Delta H_{1/2}$ (G)
NaCl	1.999	143	1.997	170	1.973	71	—	—
KF	1.991	117	1.996	107	1.993	79	—	—
KCl	1.985	65	1.995	55	1.981	79	1.976	55
KBr	1.983	157	1.982	147	1.873	256	1.862	270
KI	1.969	258	1.964	265	1.630	570	1.627	575
RbBr	1.961	471	1.967	459	1.845	261	—	—
RbI	1.956	438	1.949	447	1.634	528	—	—

*) Values measured at 7.5 °K (NaCl); 16.5 °K (KF); 7.5 °K (KCl); 15.9 °K (KBr); 9.7 °K (KI); 9.7 °K (RbBr); 8.5 °K (RbI).

**) Values measured at 1.6 °K.

According to our model, the two peaks are attributed to resonance in the ground and in the relaxed excited states of the excited (\bar{F}^*-F_0) pair. They are inhomogeneously broadened by the surrounding nuclear fields. The real *g*-factor is therefore

$$g = g_{mes} \left(1 - \frac{1}{3} \frac{\langle H_N^2 \rangle}{H_0^2} \right),$$

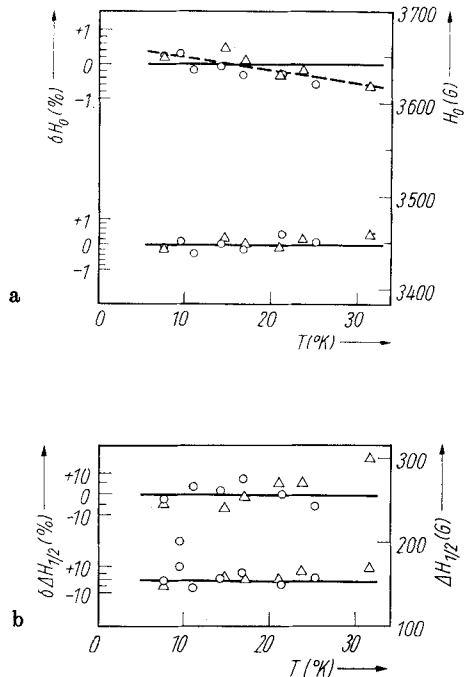
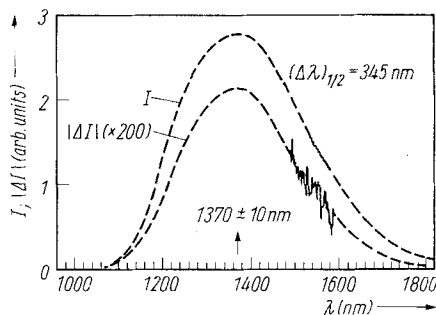

Fig. 7. a) Temperature dependence of the *g*-factors in KBr, Δ $2 \times 10^{17} \text{ cm}^{-3}$, \circ $6 \times 10^{16} \text{ cm}^{-3}$. b) Temperature dependence of the halfwidths $\Delta H_{1/2}$ in KBr, Δ $2 \times 10^{17} \text{ cm}^{-3}$, \circ $6 \times 10^{16} \text{ cm}^{-3}$.

Fig. 8. Spectral dependence of the luminescence (*I*) and the resonance peaks (ΔI) at maximum intensity for a KBr crystal at $T = 8.5 \text{ }^\circ\text{K}$.



where the nuclear magnetic field H_N is assumed to have a gaussian distribution. Consequently $\langle H_N^2 \rangle$ is related to the width at half-height of the line $\Delta H_{1/2}$ by

$$\langle H_N^2 \rangle = \frac{3}{8 \ln 2} (\Delta H_{1/2})^2 .$$

The real g -values and halfwidths are given in Table 1 together with those obtained by other authors. The error affecting the g -factor is 0.15% for NaCl, KBr, KI, and RbI, 0.25% for KF, KCl, RbBr, with 4% for the halfwidth in all crystals.

Comparing our values with those given by Seidel and Wolf [9] we observe a certain dispersion within the given accuracy. For $\Delta H_{1/2}$ the discrepancy is less or equal to ± 12 G except for NaCl for which our value is 27 G (20%) smaller. The values for KCl, KBr, and KI for the relaxed excited state are in fairly good agreement with those obtained by Mollenauer [2, 13] for isolated centres. Our g -values are however systematically larger. This can be explained by the unexpected influence of the temperature. Fig. 7 shows for KBr that the relaxed excited state g -factor has a tendency to decrease with decreasing temperature, while all the other parameter remain constant.

4.2 Resonant peak height as a function of emission wavelength

Fig. 8 illustrates the spectral variation of the luminescence and of the resonance signal alternatively analyzed for KBr by a monochromator placed in the luminescence path (Jarrell-Ash 82410, 1/4 m).

In spite of the great noise affecting the resonance signal the correspondence of the two curves is good. As expected, they are also in good agreement with the tabulated characteristics of the F centre emission in KBr [14] (Table 2).

Table 2

	emission peak position	emission half-width
tabulated	0.916 eV	0.215 eV
resonance spectra	0.9 eV	0.2 eV
luminescence	0.90 eV	0.24 eV

4.3 Effect of F centres concentration

In the same KBr sample, we have produced successively four different concentrations by irradiating the sample with X-rays at $T = 100$ °K. After each irradiation the absorption curve is measured, in order to determine the F centre concentration, and the resonance signal recorded. In all cases the incident microwave power onto the cavity is maintained at a constant level (0.3 W); the quality factor of the cavity Q has a value of 11'000 for all measurements and the temperature is held at 7.6 °K for all the concentrations. The last controllable parameter is the rate of pumping W_I . We prefer however to normalize the resonance signal to a same luminescence intensity measured at zero magnetic field. The signal defined in this way is

$$|S| = \frac{\Delta I_L}{I_L} = \frac{W_I \eta V V_t n^2 \Delta P_t}{W_I \eta V n} = n V_t \Delta P_t .$$

This formula can be checked by a log-log plot of $|S|$ as a function of the concentration. This is shown in Fig. 9 in which the straight line fitting the measurements has just a slope of unity.

Two remarks must be made concerning the measurement at high concentration:

1. The optical pumping rate W_I is not constant but decreases exponentially with the penetration depth of the light in the crystal. The result for $|S|$ is however still correct provided that the homogeneity is better for the centres than for W_I ; we have in this situation

$$|S| = \frac{\Delta P_t V_t \int W_I(x) \eta(x) n^2(x) dx}{\int W_I(x) \eta(x) n(x) dx} \approx n V_t \Delta P_t.$$

2. The KBr sample used was 1.5 mm thick and was X-irradiated in each case on the two faces. For the two lower concentrations, the X-rays were filtered by a 1 mm thick copper plate (to be added to the 3.5 mm SiO₂ of the cryostat windows). In the $6 \times 10^{16} \text{ cm}^{-3}$ case, the copper filter was only 0.3 mm thick and no filter other than the cryostat windows was used to achieve the $2 \times 10^{17} \text{ cm}^{-3}$. Thus for all the concentrations the centre distributions should be homogeneous except for the highest one which should be taken as a mean value, since the surface layer (in which most of the light is absorbed) is probably more concentrated. The corresponding representative point of Fig. 9 should be therefore pushed toward the right. No quantitative computation of this correction was made.

For all these measurements the excitation spectrum was centered at 6050 Å (400 Å FWHM).

4.4 Effect of pumping light intensity

The expression giving the variation of the luminescence intensity when the microwaves are switched on, indicates that for a low pumping rate ($W_I \ll W_{ti}$) the effect of the microwave is proportional to W_I . If W_I increases so that

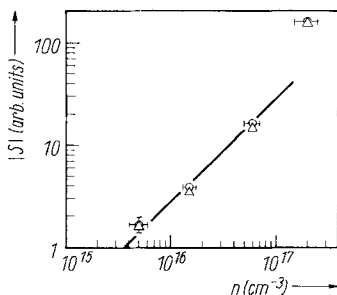

Fig. 9. Height of the resonance peaks normalized with respect to the total F centre luminescence measured at zero magnetic field versus the F' centres concentration for a KBr crystal at $T = 7.6 \text{ }^\circ\text{K}$. \circ resonance of the relaxed excited state \tilde{F}_0^* , Δ resonance of the ground state F_0 .

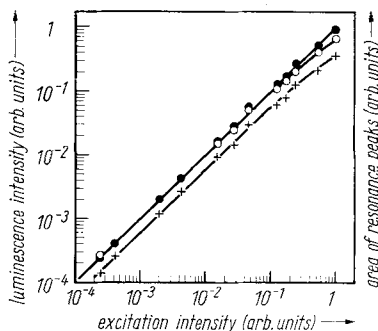

Fig. 10. Total luminescence intensity and area of the resonance peaks versus the optical excitation intensity for a KBr crystal at $T = 7.1 \text{ }^\circ\text{K}$ (arbitrary units). \bullet luminescence intensity, $+$ ground state resonance, \circ relaxed excited state resonance

W_I/W_{t1} is no more negligible with respect to unity, the signal should have a tendency to saturate.

The resonance signal was recorded with a 2 mm thick KBr crystal (13 h X-rays at 150 °K) at a fixed temperature (7.1 °K) and microwave power (0.3 W) but for different light excitation levels. By using a 200 W high pressure Hg lamp (Osram HBO 200) and a set of calibrated grey filters, it was possible to explore a range of four orders of magnitude in intensity.

Results are presented in Fig. 10 in which the full dots represent the luminescence intensity and the open circles and crosses, the surface of the resonance peaks in the excited and in the ground state, respectively. All scales are in arbitrary units. The ratio of 0.6 between both resonance peaks is not explained.

At the highest pumping rate, where a beginning of saturation appears in the resonance signal, W_I is estimated to be about 500 s^{-1} . The saturation of the resonance signal enables us to calculate the value of W_{t1} , the reverse tunnelling rate which is found to be of the order of 10^3 s^{-1} .

5. Conclusion

The F centre luminescence has been used to detect the electron paramagnetic resonance of these defects either in their ground state (F_0) or in their relaxed excited state (\tilde{F}^*), in several alkali halides. If for isolated excited centres the only way to disexcite at low temperature is radiative, for pairs of defects (\tilde{F}^*-F_0) a radiationless transition has to be taken into account since the electron in the relaxed excited state has the possibility to be transferred to its neighbour defect (F_0) via a tunnelling mechanism. This process is however forbidden for pairs having strictly parallel spins. Any change in the spin state population of a \tilde{F}^*-F_0 pairs, produced by EPR for instance, can be revealed therefore by monitoring the F centre luminescence intensity. This new, simple but powerful method should allow therefore the investigation of the relaxed excited state of numerous defects in solids.

The following predictions of the model developed in this paper and in [3] are entirely confirmed by the measurements:

1. Two resonance lines are observed and attributed to resonance in the relaxed excited state and in the ground state of the \tilde{F}^*-F_0 pair. The good coherence observed between our g and $\Delta H_{1/2}$ values and those obtained by other authors for isolated defects shows that the resonance in the electronic state of one member of a pair is not influenced in a marked way by the presence of the other partner.

2. The spectral dependence of the microwave signals measured as a function of the emission wavelength is the same as for the F centre luminescence.

3. The quasi linear dependence of the signal upon the F centre concentration shows that the phenomenon is effectively due to pairs of F centres.

4. The saturation effect observed in the relative dependence of the resonant signal upon the light excitation intensity allows us to give a mean value for the probability of the tunnelling return process toward the fundamental state F_0-F_0 .

In the next report further evidences as well as hyperfine interaction and temperature effects will be presented and discussed in detail.

Acknowledgement

The authors are indebted to Prof. F. Lüty (University of Utah, Salt Lake City) for suggestions and fruitful discussions during the time he was a visiting CICIP professor in Neuchâtel (1971).

References

- [1] S. GESCHWIND, G. E. DEVLIN, R. L. COHEN, and S. R. CHINN, *Phys. Rev.* **137**, A1087 (1965).
- [2] L. F. MOLLENAUER, S. PAN, and S. YNGVESSON, *Phys. Rev. Letters* **23**, 683 (1969).
- [3] C. JACCARD, Y. RUEDIN, M. AEGERTER, and P.-A. SCHNEGG, *phys. stat. sol. (b)* **50**, 187 (1972).
- [4] F. PORRET and F. LÜTY, *Phys. Rev. Letters* **26**, 843 (1971).
- [5] J. J. MARKHAM, R. T. PLATT, and I. L. MADOR, *Phys. Rev.* **92**, 957 (1953).
- [6] F. LÜTY, *Halbleiterprobleme*, Vol. VI, F. Vieweg, Braunschweig 1961 (p. 238).
- [7] J. A. STROZIER and B. G. DICK, *phys. stat. sol.* **31**, 203 (1969).
- [8] Y. RUEDIN, Thesis, Université de Neuchâtel/(Switzerland), 1971, unpublished.
- [9] H. SEIDEL and H. C. WOLF, *Physics of Color Centers*, Chap. 8, Ed. W. B. FOWLER, Academic Press, 1968.
- [10] D. SCHMIDT and V. ZIMMERMANN, *Phys. Letters* **27A**, 459 (1968).
- [11] P. PODINI, *Phys. Rev.* **141**, 572 (1966).
- [12] J. BEINER, Institut de Physique, Université de Neuchâtel/(Switzerland); private communication.
- [13] L. F. MOLLENAUER, S. PAN, and A. WINNAKER, *Phys. Rev. Letters* **26**, 1643 (1971).
- [14] W. B. FOWLER, *Physics of Color Centers*, Appendix B, Ed. W. B. FOWLER, Academic Press, 1968.

(Received July 28, 1972)