

PHOTOTHERMAL DEFLECTION SPECTROSCOPY FOR ULTRA TRACE ANALYSIS OF
COBALT AND COPPER IONS

Mauro H. de Paula and Michel A. Aegerter
Instituto de Física e Química, University of São Paulo
Cx. Postal 369 - 13560 São Carlos - SP - Brasil

KEY WORDS : photothermal spectroscopy, mirage effect, copper,
cobalt ions, trace analysis.

ABSTRACT

Photothermal deflection spectroscopy (PDS) is applied for the absolute determination at room temperature of ultra trace concentration of cobalt and copper ions in aqueous solution. The samples have been prepared by percolating 2 liters of solution prepared from Merck Titrisol Standards in 200 mg Merck-I cationic exchange resin. With the present experimental conditions the detection limit is 20 ppb and 200 ppb for copper and cobalt ions respectively within an overall accuracy of 5%. The response of the spectrometer has been calibrated using ICP technique.

INTRODUCTION

Absorption spectrometry utilizing photoacoustic or photothermal effects has become of major interest to study opaque solids and

liquids. Ultra low gas concentration has also been determined by these methods down to sub ppb-range¹⁻⁴; these techniques are particularly sensitive and allows high resolution measurements when the gas is at high pressure and when the optical transitions are weakly allowed⁵.

Trace analysis in liquids has been shown possible using similar techniques although fewer reports have appeared in the literature. Dovichi and Harris⁶ have first used a 4mW He-Ne laser for the determination of trace levels of Cu (II) ion in EDTA. Fe (II) ion analysis has been reported in bathophenanthrolic disulfonate⁷ using Ar laser as a source. More recently Deng et al⁸ using a laser thermal lens technique measured traces concentration of Cu(AA)₂ in several organic solvents (CCl₄, CHCl₃, benzene, methyl benzene, methanol and Co in PAN-Co (III)) achieving a minimum detectivity of 12 ppb. Using piezoelectric ceramic tube as detectors Lahman et al⁹ detected traces of β carotene in chloroform and quoted a detection limit of 0,08 ng/cm³ (corresponding to an absorption coefficient $\alpha = 2,2 \cdot 10^{-5} \text{cm}^{-1}$). Oda et al using a similar method have reported a detection limit of 0,02 ng/l (14 ppt) of Cd in Penicillium ochro-chloron¹⁰ and reported detection of MnO₄ in aqueous solution¹¹. Patel and Tam¹² using a PZT detector in a different configuration measured absorption lines of micron thick films of rare earth in aqueous solutions (concentration 0,7 to 1 g/cm³) down to an estimated fractional absorption of 10⁻⁵. The same authors¹³ using a submersed piezoelectric transducer together with a pulsed tunable dye laser reported C-H stretch band absorption of benzene with

capacity to detect absorption coefficients of the order of 10^{-7}cm^{-1} . Other liquids have also been measured recently such as Rhodamin 6G in ethanol solution with concentration 10^{-5}M to 10^{-2}M ,¹⁴ dilute aqueous solution of Congo Red dye¹⁵ and mineral oil¹⁶. Most of these measurements showed several orders better determination as compared to colorimetric technique.

In the present communication, we report the spectroscopy determination of traces of Cu and Co ions in aqueous solution which have passed through a Merck I Cation exchange resin down to a detection limit of 20 ppb, using a double beam photothermal deflection technique (mirage effect) in transverse configuration^{17,18}.

EXPERIMENTAL

The double beam mirage effect spectrometer in transverse configuration is shown in Fig. 1. It detects the deflection of a low power HeNe laser beam propagating parallel to the surface of the sample within a layer of thickness equal to the thermal diffusion length μ_q . The deflection is caused by the periodic change of the index of refraction n of the gas or the liquid in front of the sample which is a measure of the periodic change of the temperature gradient occurring when light is absorbed by the sample¹⁷. The temperature gradient has already been calculated for various combination of sample/gas or sample/liquid interface as a function of the thermal, acoustical and optical parameters¹⁷⁻¹⁹.

The excitation beam consists of an Oriel Xe lamp 450W (Model 6163/6261) coupled to a driven high intensity Bausch and Lomb monochromator (33-86-25). The wavelength range of 200-1600 nm is co-

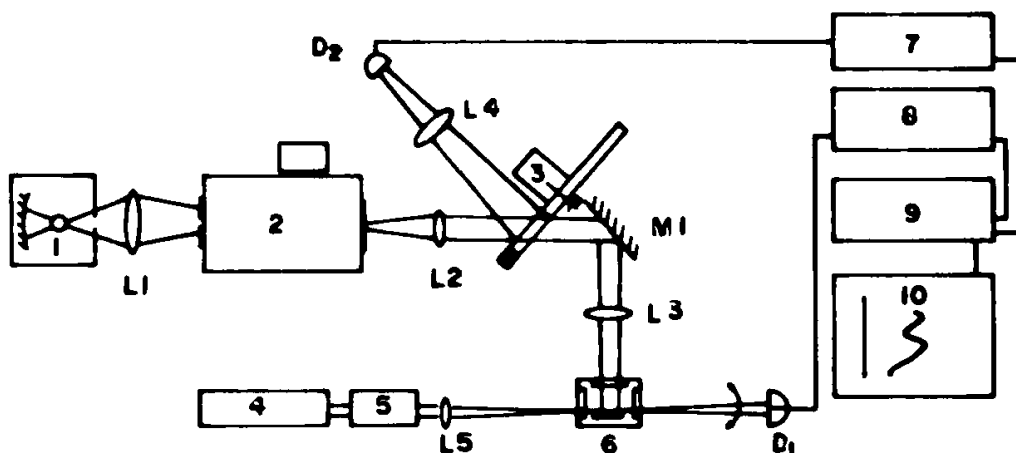

FIG.1 - Experimental set-up for the double beam photothermal spectrometer (1) 450W Xe lamp (Oriol 6163/6261) (2) Monochromator (Bausch + Lomb (33-86-25 + grating 338679 (UV-visible) and 33-86-77 (IR 1)) (3) Chopper 13 Hz with special blade (EGG 125 A) (4) HeNe Laser 1mW (Spectra Physics 236) (5) Beam reducer (6) Stainless steel sample cell with 3 Suprasil quartz windows (7) Lock-in EGG 5204 (8) Lock-in EGG 124 A (9) Ratiometer EGG 5204/96 (10) Recorder (L₁ to L₅)Suprasil quartz lenses (M₁) Al high reflectance mirror (D₁)Lateral cell detector (Centronix LD 2-5T, Sample beam (D₂) PZT detector (reference beam) (F₁) filters to eliminate unwanted 2nd order light excitation.

vered by two gratings UV-Vis (338679) and IR 1 (338677) and various filters to eliminate second order diffraction. The beam is chopped at 13.8 Hz by a modified 125 A EGG chopper; one side of the blade is covered with a high reflectance Al mirror in order to divide the excitation light beam: the beam reflected by the mirror-blade is focused on a 15 mm diameter PZT detector whose first surface is black painted. The detector has a response proportional to the light intensity (0,16 V/W) and is used as reference signal to normalize the photothermal response. The signal reference is analysed by an EGG 5204 lock-in. The beam passing through the chopper is optically equivalent and is focused on the sample placed in a stainless steel

cell which can be precisely adjusted in the two orthogonal horizontal directions with micrometers. The maximum intensity received by the sample is of the order of 8 mW at $\lambda = 1\mu\text{m}$.

The probe beam consist of a collimated 1 mW Spectra Physics Model 236 HeNe laser having a diameter of 2mm and focused parallel to the sample by a convex lens. The periodic deflection of the laser is measured by a lateral position detector (Centronic LD 2-5T) which consists of 2 cells 2 X 0,5 mm separated by 0,5mm. The light intensity measured by the two cells is fed to a differential EGG 116 preamplifier and analysed by an EGG 124 A lock-in. The dc outputs of the two lock-in (signal + reference channels) are then divided by an EGG 5204/96 ratiometer and the normalized ratio is registered grafically as a function of the wavelength. A careful study of the performances of the spectrometer has been done²⁰. It allows to detect a probe beam deflection of the order of 10^{-7} rad for a signal to noise ratio $S/N = 1$ which corresponds to a periodic temperature variation at the solid-liquid interface of $7 \cdot 10^{-6}\text{K}$. The optical resolution is of the order of 1.6 nm in the visible range and is mainly limited by the monochromator (dispersion of 6,4 nm/mm in the UV-visible and 12,8 nm/mm in the near IR).

Each sample has been prepared by percolating 2 liters of solution through 200 mg of wet highly acid cationic exchange resin Merck I. The column had a diameter $d = 4\text{mm}$ and a height $h = 15\text{mm}$; the flow rate was 10 ml/min. The solutions have been prepared by diluting standard Titrisol Merck solutions in deionized water with a pH = 6. After completing the percolation the resin was dried and mixed in an agate crucible and then pressed in pills form ($\emptyset 7 \times 1\text{mm}$).

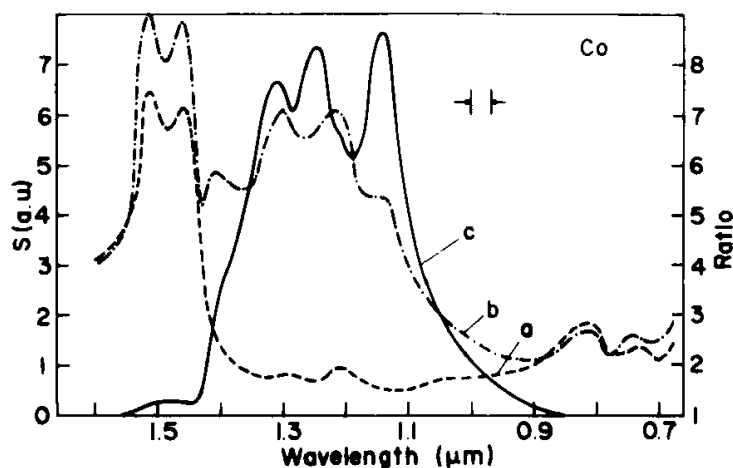

FIG.2 - Double beam photothermal deflection (left scale) of a Merck I cationic resin percolated with pure deionized water (curve a), and with 2 liters 45 ppm Cobalt aqueous solution (curve b). Both curves have been normalized to 1 at $0,88 \mu\text{m}$. Curve c (right scale) is the ratio of curve b to curve a.

In order to increase the photothermal signal the cell was filled with CCl_4 . This liquid is transparent in the whole spectral range investigated (240-1600 nm) and does not effect the optical properties of the sample.

RESULTS

The double beam photothermal deflection spectrum of the resin percolated with pure deionized water and measured between $0,7 \mu\text{m}$ and $1,6 \mu\text{m}$ is shown in Fig. 2 (curve a). The origin of the peaks has not been studied. Curve b is an example of the photothermal spectrum of the resin percolated with an aqueous solution of 45ppm cobalt ions in the same experimental conditions. Curves a and b have been normalized to the same value at $0,88 \mu\text{m}$. Curve c is the ratio of curve b to curve a. A comparison of the three curves shows that the relative height of the bands which belong to the matrix

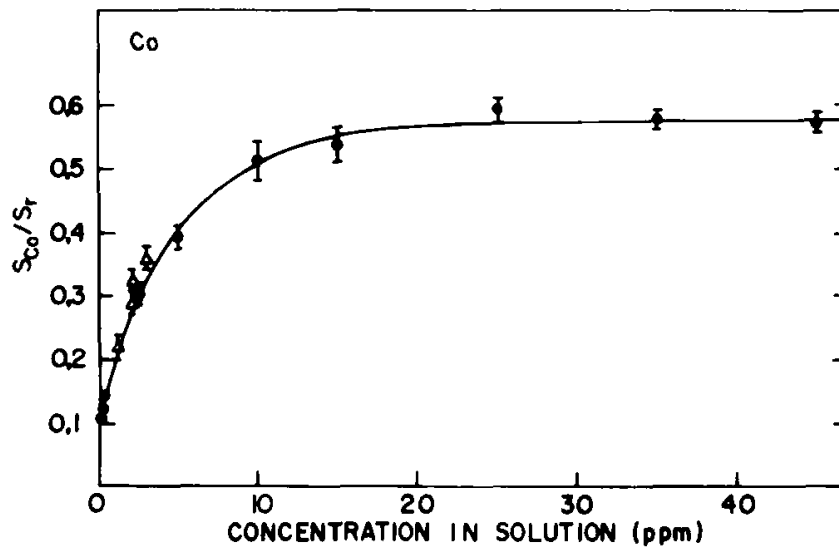

FIG.3 - Photothermal deflection ratio S_{Co}/S_r as a function of cobalt ions concentration in the solution. The signals S_{Co} and S_r are measured single beam for light absorption at $\lambda = 1785$ nm and $\lambda = 915$ nm respectively. The experimental points (\bullet , Δ) refer to two different Merck Titrisol standards and their values are a mean of four measurements. The line has been drawn through the points.

only does not change when the foreign ions are incorporated since the ratio of both curves is constant (approximately one) in the spectral region $\lambda < 0,9 \mu\text{m}$ and $\lambda > 1,45 \mu\text{m}$. Consequently the bands appearing between 1 and 1,4 μm are attributed to the presence of cobalt ions in the resin and their heights or areas may be used as a measure of the cobalt concentration in the resin. However, the absolute signal values depend of several geometrical factors such as the probe beam offset, the sample tilt angle as well as the excitation light intensity and it is rather difficult to adjust the geometrical parameters to the same values after exchanging the samples; therefore a direct comparison of the samples with different concentrations is rather impossible. Fortunately

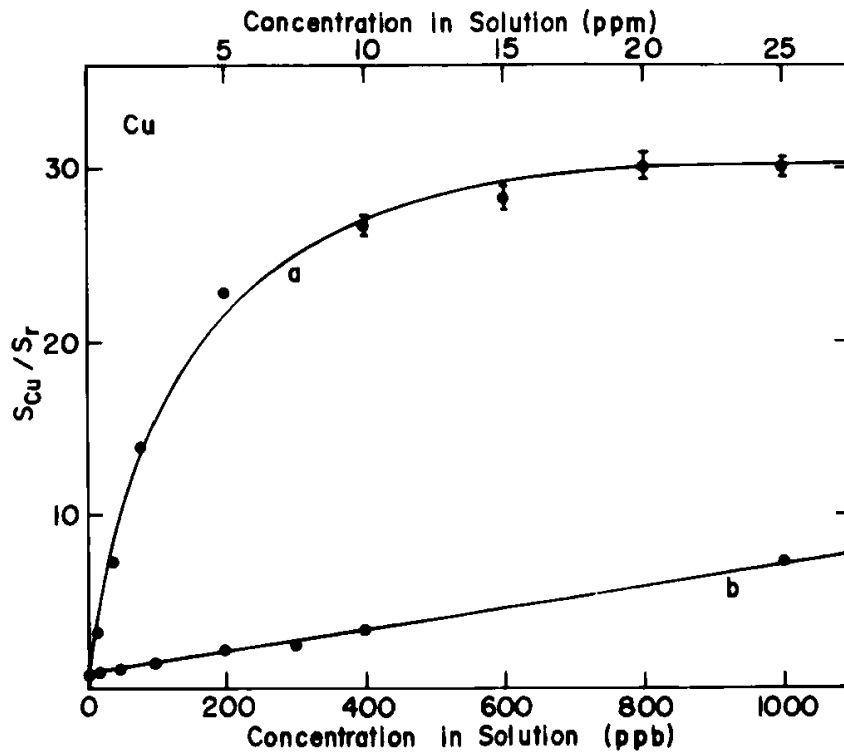

FIG.4 - Photothermal deflection ratio S_{Cu}/S_r as a function of copper ions concentration in the solution. The signals S_{Cu} and S_r are measured single beam for light absorption at $\lambda = 895\text{nm}$ and $\lambda = 1475\text{nm}$ respectively; curve a (upper scale), curve b (lower scale). Each experimental point is the mean of four measurements and the line has been drawn through the points.

figure 2 shows that the cobalt ions absorb in a spectral region different of that of the pure resin and that the resin photothermal peaks are not affected by the incorporation of the ions. It is therefore possible to make a relative comparison between the samples with different concentrations.

Fig. 3 shows the results of such a comparison for various cobalt concentrations in solution varying between $0 \leq C \leq 45\text{ppm}$. We have plotted the ratios $S = S_{Co}/S_r$ of the single beam photothermal signal value S_{Co} taken at $\lambda = 1285\text{ nm}$ due to the cobalt + resin

to the photothermal signal value S_r taken at 915 nm due to the resin only. Each point represents the average of four measurements of the same sample. The full curve has been drawn through the experimental results. The offset at zero concentration is due to the fact that the pure resin has a structureless background at the wavelength of the Cobalt bands (fig. 2). The ratio tends to saturation for solution concentration $C > 10$ ppm.

Similar results have been obtained for Copper ions in aqueous solution. Absorption bands appeared around 890 nm and are attributed to the presence of copper ions absorbed in the resin. Measurements as a function of the concentration shows that the relative photothermal signal $S = S_{Cu}/S_r$, where S_{Cu} is the single beam photothermal signal due to Cu absorption taken at 895 nm and S_r is the single beam photothermal signal of the pure resin taken at 1475 nm tends also to saturate for concentration $C > 10$ ppm (fig. 4). The photothermal signals for copper are higher than for Cobalt and allow a detection with better precision and for much lower concentration. The copper solution percolated has been analyzed by ICP technique in order to know exactly the amount of ions which have been effectively absorbed by the resin. The analysis shows that the resin absorbs roughly 50% of the ions for aqueous concentration up to 5 ppm. For higher concentration its absorption power tends to diminish till it reaches the saturation. The resin is totally saturated for $C > 10$ ppm. Figure 5 shows the same relative photothermal signal S_{Cu}/S_r plotted now against the concentration of copper ions in the resin measured in ppm of the solution (upper

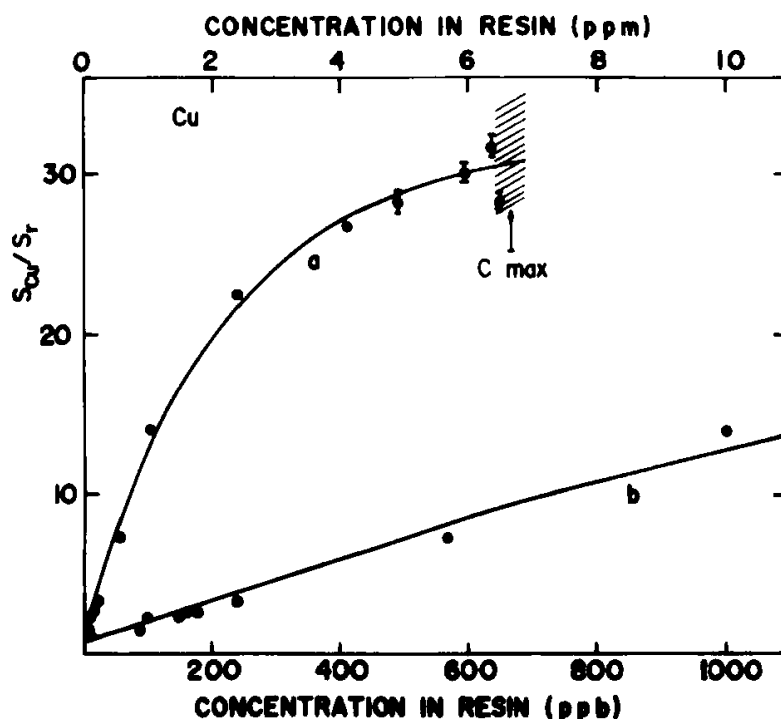

FIG.5 - Photothermal deflection ratio S_{Cu}/S_r (see fig. 4) as a function of copper ions concentration in the resin (see fig. 4); curve a (upper scale), curve b (lower scale). The mark C_{max} refers to the maximum concentration absorbed in the resin.

scale) (1 ppm corresponds to 2 mg Cu absorbed by the 200 mg of the resin). The behavior is not linear. The lower curve shows the same results in a 1000 X expanded scale (ppb). The full curves have been drawn through the experimental points.

The fact that the photothermal signal is not linear as a function of the concentration can be at this stage qualitatively understood. The theory of the photothermal deflection developed recently by Murphy and Aamodt¹⁹ explains that the signal intensity depends essentially of two physical parameters: the optical length penetration in the sample $\mu_\beta = \beta^{-1}$ where β is the sample bulk optical absorption coefficient and the thermal diffusion length $\mu_s = a_s^{-1}$

TABLE I

Values of the Parameters for the Resin and pure Metals

	K_s (cal/cm s °C)	μ_s (at 13.8Hz) (cm)	β (cm ⁻¹)	μ_s/K_s (cm ² s °C/cal)
Resin ²¹	$2.6 \cdot 10^{-4}$	$1.3 \cdot 10^{-3}$	100	4,9
Copper ²²	$9.3 \cdot 10^{-1}$	$1.6 \cdot 10^{-1}$	\gg	0,17
Cobalt ²²	$1,65 \cdot 10^{-1}$	$6,5 \cdot 10^{-2}$	\gg	0,40

where a_s is the thermal diffusivity of the material. Our samples (thickness 1-1mm) are thermally thick, i.e. $a_s \cdot l \gg 1$ and optically thick ($\beta l > 1$, typically > 4) in the wavelength region of interest. According to ref. 19, if $|\beta \mu_s| < 1$ the photothermal signal is proportional to $\frac{\mu_s}{K_s} (\mu_s \cdot \beta)$ where K_s is the thermal conductivity and if $|\beta \mu_s| > 1$ the signal is proportional to $\frac{\mu_s}{K_s}$ and does not depend any more of the optical absorption coefficient.

With the parameters of the table 1 we see that the ratio $\frac{\mu_s}{K_s}$ will certainly slightly decrease as the concentration of the metal ions absorbed increases. On the other side, the parameters μ_s and β will increase with the concentration with a much larger variation. Since the range of concentration of metallic ions in the resin is small (up to a few ppm only), we can reasonably assume in first approximation that $\frac{\mu_s}{K_s} \propto \frac{1}{C}$, $\mu_s \propto C$ and $\beta \propto C$. For the pure resin the product $\beta \mu_s$ is of the order of 0.13 (< 1). Therefore for very low concentration, as long as $|\beta \mu_s| < 1$, the photothermal signal will increase linearly with the concentration of

the metal in the resin. But as the product $|\beta\mu_s|$ increases, the rate of increase of the signal will diminish and the signal will pass by a maximum for $|\beta\mu_s|$ somewhat large than 1 and then decrease proportional to the ratio $\frac{\mu_s}{K_s}$. This should happen for concentration much higher than the concentration which can be physically absorbed by the resin. Experimentally the figures 2 and 3 show effectively that S initially increases linearly with the amount of metal incorporated in the resin and then tends to saturate. The third range is not observed. Detailed quantitative calculations are underway to corroborate the model and will be presented elsewhere.

Under the actual experimental conditions the minimum concentration detectable is of the order of 200ppb Co and 20 ppb Cu (concentration in aqueous solution). A careful check of our spectrometer has shown that the noise registered during these experiments at 13,8 Hz is essentially of acoustic origin. It corresponds to a deflection of the probe beam of 10^{-7} radians. However Jackson et al¹⁸ reported a spectrometer performance based on a similar set-up, in which the ultimate noise was essentially limited by the pointing fluctuation of the laser probe corresponding to a deflection of 10^{-9} radian only. We think that an improvement by a factor 10 can be obtained using better equipment such as an antivibration table, control of air convection, etc. On the other hand the photothermal signal is proportional to the excitation intensity; a considerable improvement can therefore be obtained using better spectral sources like interference filters or variable frequency lasers. Moreover the response of the spectrometer is almost inversely proportional

to the chopping frequency of the light excitation. We used a frequency of 13,8 Hz for convenience; however this can be lowered to a few Hertz without loosing the performance of the lock-in amplifier and gain a factor of 3 on the signal/noise ratio. We therefore believed that taking into account of these factors we can drastically improve the results allowing a better and more precise detection of the photothermal deflection and pushing the detection limit well below the ppb range for copper and cobalt ions.

This method has been applied successfully to other ions such as Ni. However ions such as Cd, Zn and U did not give any result because we did not find in the 0,7 - 1,6 μm spectral range any bands of thermal deflection which can be attributed to these ions.

This new method has very interesting advantages over other photoacoustic techniques such as for instance the thermal lens effect since it allows the spectroscopic detection of particular ions and if several ions are absorbed together they can in principle be detected as long as their spectroscopic photothermal absorption bands are separated, as it is the case for instance for Co and Cu. If only one metallic ion must be detected routinely, the experimental set-up may be considerably simplified by using interference filters instead of a monochromator, cheaper and better adapted optical sources and electronics such as fixed narrow frequency amplifiers instead of sophisticated lock-in amplifier. Moreover since the reagents act as a storage element even lower concentration can be measured if larger amount of aqueous solution is available. For instance under our experimental conditions, percolating a 20 liters

aqueous solution containing 10 ppb Cu will give the same result as if we percolate a 2 liters solution containing 100 ppb Cu, since the amount of copper absorbed by the sample will be the same (200 μ g).

This method has however some disadvantages. The time required for the preparation of the samples (percolation and mixing) is relatively long. Improvement may be thought using percolation under pressure or using other substrate as storage media; a good candidate is porous glass which is totally transparent in the UV-near infrared spectral region and absorb very rapidly any liquid solution up to 20-30% in weight.

CONCLUSION

We have presented a new and potentially very important method to determine quantitatively ultra trace analysis of ions in aqueous solution. The method uses simple photothermal spectrometer and has been successfully applied to the detection of Co, Cu, Ni ions. No results have been obtained for Cd, Zn and U.

With the present equipment the detection limit for a signal/noise ratio of one was 20 ppb for Cu and 200 ppb for Co. Improvement of the spectrometer are expected to lower these limits by -2 orders of magnitude and better storage media may reduce considerably the time necessary to complete one determination. Studies are underway to solve both ultra trace proposals and to corroborate quantitatively the model using the theory of Murphy and Aamodt¹⁹.

ACKNOWLEDGMENT

This work has been partly supported by FAPESP, FINEP and CNPq.

One of us (M.H.P.) is grateful to the Comissão Nacional de Energia Nuclear (CNEN) for receiving a scholarship.

REFERENCES

- 1) L.B.Kreuzer, *J. Appl. Phys.*, 42 2934 (1971).
- 2) L.G.Rosengren, *Appl. Opt.*, 14 1960 (1975).
- 3) E.Kritchman, S.Shtrikman and M.Slatkin, *J. Opt. Soc. Am.*, 68 1257 (1978).
- 4) D.Sourlier and O.Oehler, *J. de Physique, Colloque C6 Suppl. au No 10, 44* C6-587 (1985).
- 5) Ch.J.Bordé, *J. de Physique, Colloque C6, Suppl. au No 10, 44* C6-593 (1983).
- 6) N.J.Dovich and J.M.Harris, *Anal. Chem.*, 51 728 (1979).
- 7) T.Imasaka, *Anal. Chim. Acta*, 115 440 (1980).
- 8) Y.Deng, R.Sheng and M.Wang, *J. de Physique, Colloque C6, Suppl. au No 10, 44* C6-587 (1983).
- 9) W.Lahmann, H.J.Ludewig, H.Welling, *Anal. Chem.*, 49 549 (1977).
- 10) S.Oda, T.Sawada and H.Kamada, *Anal. Chem.*, 50 865 (1978).
- 11) S.Oda, T.Sawada and H.Kamada, *Bunseki Kagaku*, 27 (1978).
- 12) C.K.N.Patel and A.C.Tam, *Appl. Phys. Letter*, 36 7 (1980).
- 13) C.K.N.Patel and A.C.Tam, *Appl. Phys. Letter*, 34 467 (1979).
- 14) G.Schneider and U.Röller, *J. de Physique, Colloque C6, Suppl. au No 10, 44* C6-407 (1983).
- 15) R.N.Mathur and G.C.Pandey, *J. de Physique, Colloque C6, Suppl. au No 10, 44* C6-171 (1983).
- 16) G.Rousset, J.P.Monchalin and L.Bertrand, *J. de Physique, Colloque C6, Suppl. au No 10, 44* 164 (1985).
- 17) J.Badoz, D.Fournier and A.C.Boccaro, *J. Optics*, 11 399 (1980).
- 18) W.B.Jackson, N.M.Amer, A.C.Boccaro and D.Fournier, *Appl. Optics*, 20 1333 (1981).
- 19) J.C.Murphy and L.C.Aamodt, *J. Appl. Phys.*, 51 4580 (1980).
- 20) M.H.Paula and M.A.Aegerter, to be published.
- 21) J.Brandrup, E.H.Immergut, *Polymer Handbook*, 2nd edition, Wiley Interscience (1975).
- 22) *International Critical Tables of Numerical Data: Physics, Chemistry and Technology*, National Research Council, McGraw-Hill (1933).

Received July 24, 1985

Accepted January 9, 1986