

An open-ended photothermal cell for *in vivo* measurements

M. H. De Paula,^{a)} M. A. Carvalho,^{b)} L. M. Alves, and M. A. Aegerter

Instituto de Física e Química de São Carlos, Universidade de São Paulo, Cx. Postal 369, 13560 São Carlos (SP), Brazil

(Received 23 September 1986; accepted for publication 13 November 1986)

A new photothermal open-ended cell particularly adapted for *in vivo* spectroscopic measurements is described. The detector is a transparent LiNbO₃ crystal or a crystalline quartz transducer in direct contact with the sample. The cell can be attached to an optical fiber cable for light excitation. The cell has a high signal-to-noise ratio and its frequency variation is proportional to $\omega^{-1.16}$. *In vivo* and *in vitro* measurements performed on green leaf and carbon black samples are presented.

I. INTRODUCTION

In the past few years the field of photoacoustic and photothermal spectroscopies has been widely developed and numerous applications have appeared in solid-state physics, photochemistry, nondestructive testing, etc.^{1,2} The physical principles are the same for all the methods. When electromagnetic radiation is absorbed by a sample, a significant fraction of the incident energy is generally converted into heat. This induced heating is usually detected by measuring either the correlated pressure variation induced in a closed cell by a sensitive microphone or the thermally induced vibration of a piezoelectric transducer.³

The photothermal deflection spectroscopy (mirage effect) is another useful and very sensitive technique developed by Badoz, Fourier, and Boccarra⁴; it eliminates the necessity to keep the sample in a closed cell and it is therefore free of spurious photoacoustic signals generated at the absorbing walls of the cell by the light scattered by the sample and the windows. In this case the signal is detected by the change of the index of refraction produced in a very thin layer of the fluid (gas or liquid) near the sample by the temperature variation of the sample. A low-power He-Ne laser probe beam focalized near the sample is therefore deflected. This detection technique is slightly more sensitive than the conventional microphone detection.

Photothermal displacement spectroscopy is a related technique especially useful when the experimental conditions of both photoacoustic and photothermal deflection are unsuitable for studying optical and thermal properties. Its sensitivity is somewhat smaller than the mirage effect but comparable to the microphone detection. Examples are experiments which require ultra-high vacuum, cryogenic temperature, or *in situ* and real-time characterization. Optical heating of the sample results in the buckling and displacement of the illuminated surface. A measure of this displacement is a means for determining the optical and thermal properties of the sample. Several experimental configurations have been described by Amer.³

Another powerful and related technique is the thermal lensing effect, first reported by Gordon *et al.*⁵: this effect arises from the transverse gradient of the refraction index caused by nonuniform heating associated with radiationless transitions. A probe laser beam passing through a sample is defocused by the effect induced by a heating beam; the intensity of the probe beam is decreased at its center. In pulsed photoacoustic experiments, piezoelectric detectors such as PZT, LiNbO₃, crystalline quartz, PVF₂ films, etc.^{6,7} in direct contact with the samples show extremely high sensitivity for detecting weak absorption in liquids and solids. These detectors, however, are also very sensitive to electromagnetic radiations from the infrared⁸ to the x-ray spectral range^{9,10}; therefore, care must be taken for the mounting of the samples in order to prevent scattered radiation and excited luminescence from reaching the transducer since these induced signals can mask the true photoacoustic response of the sample. These are preferred to microphones for pulsed photoacoustic studies in condensed matter because of the much faster rise times and the much better acoustic impedance matching, although their sensitivity is typically 1000 times smaller than a sensitive microphone.

Rosenzweig¹¹ has mentioned the feasibility of performing *in vivo* measurements of human skin using an open-ended cell, in which the open side is sealed against the specimen to be studied. A few experimental devices using a microphone as a detector have been already tested.¹²⁻¹⁴ The major difficulty lies in the fact that the microphone is sensitive to the body's movements. Poulet and Chambron¹⁴ solved this problem by building a photoacoustic detector using a differential microphone between two identical cells, allowing *in vivo* cutaneous measurements with reasonably good reproducibility and signal-to-noise ratio (~ 200 at 25 Hz). Helander¹⁵ and McQueen^{16,17} have proposed two configurations using a sapphire plate bound to a piezoelectric transducer that is well suited for liquid and powder measurements.

This paper reports the design of a simple open-ended cell using as a detector a transparent piezoelectric transducer. It allows *in vivo* studies and photoacoustic measurements of samples which cannot be conveniently adapted to conventional cells. Its high sensitivity renders the cell also quite attractive for studies of solid materials. Its spectral

^{a)} Present address: UAPDIA (Unidade de Apoio à Pesquisa e Desenvolvimento de Instrumentação Agropecuária), EMBRAPA (Empresa Brasileira de Pesquisa Agropecuária), Cx. Postal 741, 13560 São Carlos (SP), Brazil.

^{b)} On leave from Electrical Engineering Department, F.E.I.S., UNESP, Cx. Postal 31, 13378 Ilha Solteira (SP), Brazil.

range is defined by the spectral range of the transmittance of the transducer.

II. EXPERIMENTAL SETUP

The prototype open-ended cell is shown schematically in Fig. 1. The key element is the transparent transducer. Up to now only two elements has been tested: LiNbO_3 (Ref. 18) and crystalline quartz. Their sizes were typically ϕ 12.5 mm \times 1.5 mm. The faces were cut and optically polished perpendicular to the X crystallographic axis. The electrodes are ring shaped and made from silver paint. As they are particularly fragile and easily removed, they are protected using an insulating glue. We believe that an improvement can be obtained by the correct choice of the transducer thickness and using evaporated metallic ring electrodes or transparent ITO electrodes sputtered over the whole surface.

The double-beam spectrometer is shown in Fig. 2; it is mounted on two separate tables. One of them is especially well isolated acoustically and can hold various optoacoustic detectors [photoacoustic cell with microphone, thermo-optical cell¹⁹ (mirage effect), etc.]. It is interesting to note that the reference beam is detected by a homemade and inexpensive piezoelectric detector whose first electrode is covered by a layer of carbon black giving a flat spectral responsivity of 345 mV/W for chopped light detection at 6.47 Hz in the 250–3200-nm spectral range.

The new detector is either mounted on this table for *in vivo* or *in vitro* studies of small samples or connected to an optical fiber cable (diameter 6 mm, length 1.2 m). The length of the optical cable is not limited to the one presently used. This renders the cell quite attractive for performing measurements on samples that are difficult to access in a laboratory or even outside of the laboratory (for example, for tests on living plants, nondestructive tests in field, etc.).

Because of the impedance of the transducer, care should be taken to adapt a field-effect transistors (FET) preamplifier as close as possible to the detector in order to eliminate spurious electrical pick-up by the detector cable. In our case we used an EGG-PAR Model 114 conditioner together with a 1-G Ω Model 185 preamplifier; we believe that a battery-

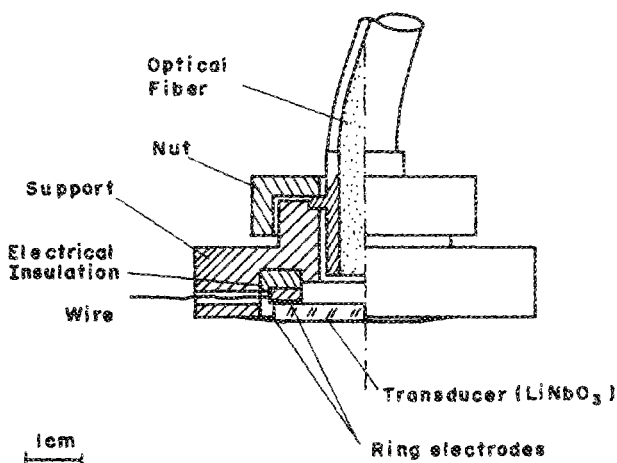

FIG. 1. Schematic representation of the open-ended cell attached to an optical fiber cable ($\phi = 6$ mm) for light excitation.

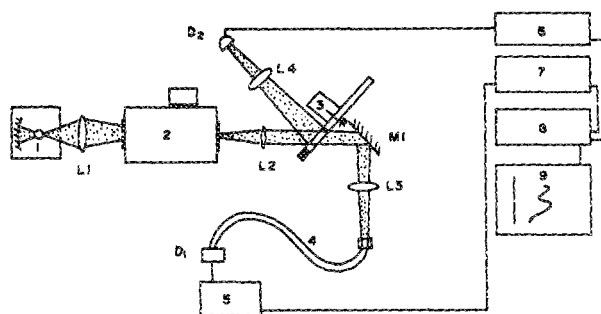

FIG. 2. Schematic representation of the experimental double beam photoacoustic spectrometer: (1) Xe lamp, Bausch & Lomb 150 W; (2) high-intensity monochromator, Bausch & Lomb; (3) modified chopper EGG 194 with Al-coated mirror blade on the front side; (4) optical fiber cable; (5) preamplifier EGG 185/114; (6) lock-in EGG 124-A; (7) lock-in EGG 5204, with built-in ratiometer (8); (9) recorder ECB 102. (L_1 – L_4) quartz lenses, (M_1) front surface mirror Al coated, (D_1) photoacoustic cell with LiNbO_3 or quartz transducer, (D_2) PZT detector (reference beam).

operated FET electrometer built into the cell will give similar results but allow greater flexibility and easier handling.

III. EXPERIMENTAL RESULTS

A. LiNbO_3 transducer

The cell has been initially tested in an *in vitro* experiment with a carbon black sample pressed with a small clamp directly on the transducer. Figure 3 shows the uncorrected (single beam) spectrum in the UV-visible region measured with a monochromator resolution of 9.6 nm and at a chopping frequency of 27.5 Hz. The lower limit of the spectral range of the cell is 310 nm due to the light absorption of the LiNbO_3 transducer. Figure 4 shows the response of the cell as a function of the incident light power under the following experimental conditions: $\lambda = 915$ nm, frequency 6.47 Hz. The light power was measured with the homemade PZT detector¹⁰ having a response of 345 mV/W. The response is linear and proportional to the light power for at least three orders of magnitude. The signal-to-noise ratio is excellent,

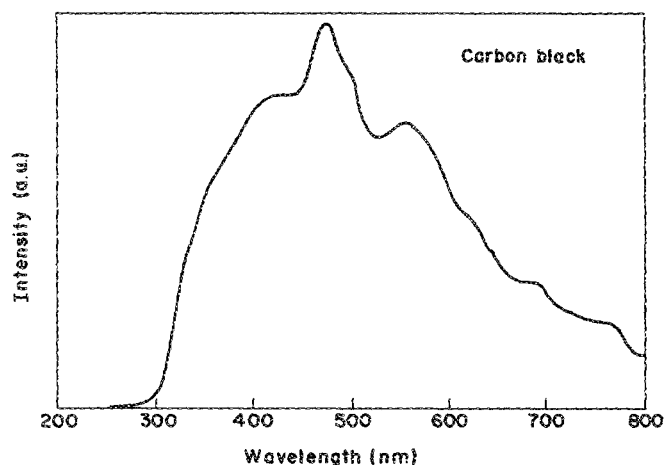

FIG. 3. Uncorrected response of the photoacoustic cell to carbon black sample measured in single-beam configuration. Chopper frequency 27.5 Hz, spectral resolution 9.6 nm.

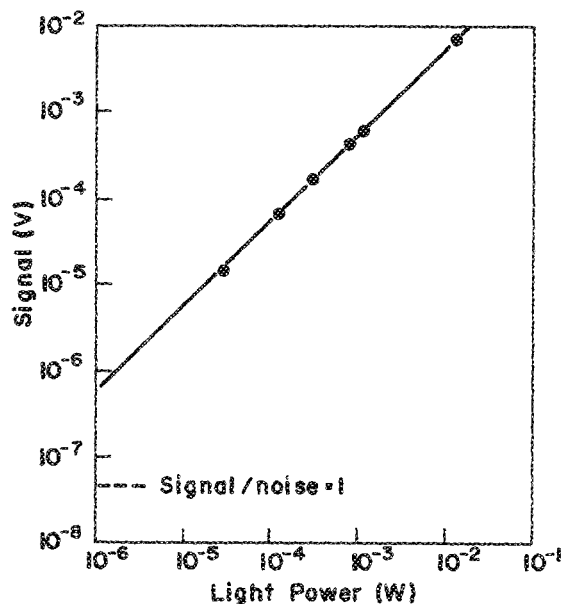

FIG. 4. Response of the photoacoustic cell as a function of the incident light power measured at a chopping frequency $\omega = 6.47$ Hz and $\lambda = 915$ nm. The horizontal dotted line gives the level of the signal for a signal/noise = 1 using a 1-Hz bandwidth.

allowing measurements with incident light power down to less than 10^{-7} W (signal-to-noise ratio = 1 at 1 Hz bandwidth).

Comparative measurements made under the same experimental conditions with the new cell, a conventional PZT detector, and a microphone cell shows that the signals are in the ratio 1:0.6:2.4, respectively.

The dependence of the signal and its phase measured as a function of the frequency with the carbon black sample in the same experimental conditions is shown in Fig. 5. For these measurements the phase was always adjusted in order to give the maximum signal value. The signal is proportional to $\omega^{-1.16}$. The phase difference shows a strong frequency variation which is not yet clearly understood. At higher frequencies the thermal wave which is incident from the sample inside the transducer is limited to a very small layer very close to the sample, but when the frequency is decreased the thermal wave penetrates more and more into the transducer. As the transducer is mechanically bonded on its circumference and relatively thick (1.6 mm) we believe that its deformation may change with chopping frequency and affect the phase of the signal. On the other hand, structural imperfections across the transducer may also affect this parameter. Further tests are underway with transducers of different thicknesses in order to resolve this problem.

Figure 6 shows the results of an *in vivo* measurement using the double-beam spectrometer (correction for the spectral intensity variation from the light source included) made on a green leaf of "Polypodium Adiantum" using a frequency of 27.5 Hz and a spectral resolution of 9.6 nm. The cell was clamped to the leaf still attached to the plant. A comparison is made with an *in vitro* measurement made with the intact leaf but removed from the plant. Both signals are similar and have a spectral behavior analogous to those ob-

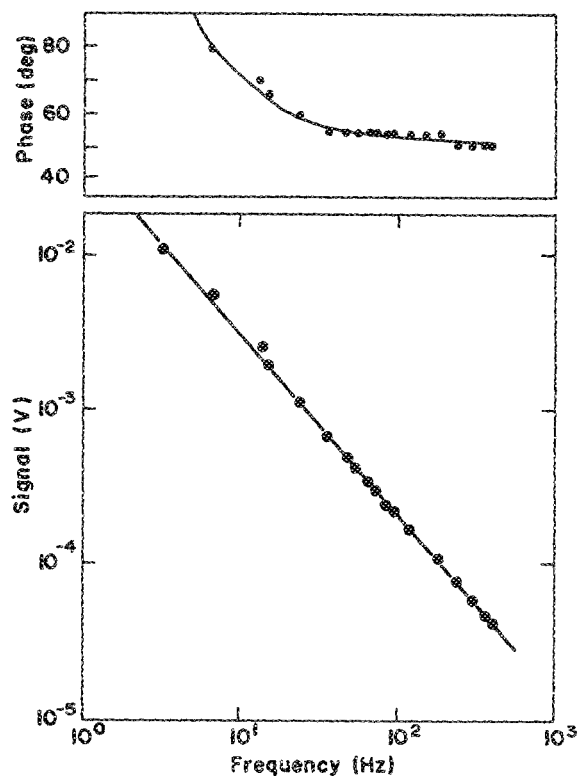

FIG. 5. Variation of the signal intensity and the phase difference as a function of the chopper frequency. The straight line has a slope of -1.16 . In the upper figure a solid line has been drawn through the data to guide the eye.

served by Rosencwaig,²⁰ Merle and co-workers,²¹ and Veeranjanyulu and Das²² showing the optical characteristics of the chloroplasts of the leaf matter such as the chlorophyll band between 600 and 720 nm. It is remarkable that the signal-to-noise ratio is excellent for both spectra.

B. Quartz transducer

Basically the same results have been obtained with a cell having a disk-shaped crystalline quartz transducer. The dispersive is, however, 80 times less sensitive than the LiNbO_3

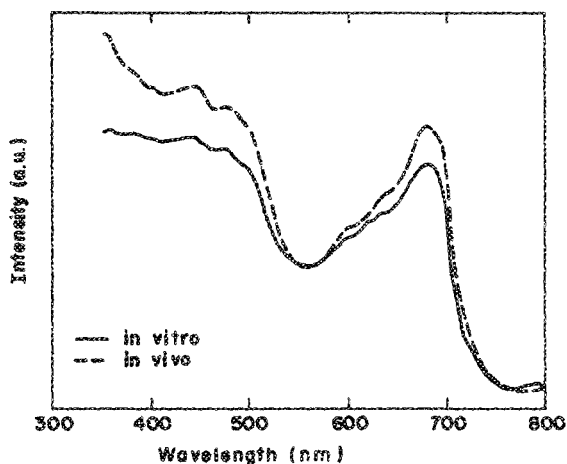

FIG. 6. *In vivo* and *in vitro* double-beam measurements of the photoacoustic response of a green leaf of "Polypodium Adiantum." Chopper frequency 27.5 Hz, spectral resolution 9.6 nm.

cell but nevertheless can be extremely useful for measurements to be performed in the near UV spectral region $220 \text{ nm} < \lambda < 320 \text{ nm}$.

IV. CONCLUSION

The new cell described here is simple and relatively inexpensive, has a great potential for *in vivo* photoacoustic measurements, and exhibits several distinct advantages over previous devices.¹⁰⁻¹⁵ However, the cell is not limited to such investigation and can also be used for *in vitro* measurements with solid materials having even larger dimensions and probably also for liquid samples. Its spectral range is limited in the UV range down to $\sim 320 \text{ nm}$ because of the absorption of the incident radiation by the transducer. The spectral response can be extended down to $\sim 200 \text{ nm}$ using a crystalline quartz element; however, the signal intensity is reduced by a factor of 80. The signal-to-noise ratio is excellent and comparable to a conventional microphone photoacoustic cell with the advantage that the new device is open-ended. The prototypes used for this report have not yet been optimized and higher sensitivity should be possible by providing a better thermal coupling between sample and transducer. Other pyroelectric transducers such as TGS and LiTaO_3 are presently under test.

ACKNOWLEDGMENTS

This research was supported by Research contracts with "Financiadora de Estudos e Projetos" (FINEP), the "Fundação de Amparo à Pesquisa do Estado de São Paulo" (FAPESP) and the "Conselho Nacional de Desenvolvimento Científico e Tecnológico" (CNPq). We are also indebted to Professor Dr. J. P. Andreeta of the Crystal Growth Laboratory of our Institute who kindly provided the sample of LiNbO_3 and to J. Marcondes for technical assistance. M. H. de Paula is grateful to Professor Dr. S. Mascarenhas (UAP-DIA/EMBRAPA) for his incentive in the realization of this work.

- ¹E. Luscher, P. Korpium, H. J. Conful, and R. Tilgner, editors, *Photoacoustic effect, Principles and Applications: Proceedings of the First International Conference on the Photoacoustic Effect* (Germany) (Vieweg, Braunschweig, FRG, 1984).
- ²J. Badoz and D. Fourier, editors, *Spectroscopie Photoacoustique et Photothermique: Third International Topical Meeting on Photoacoustic and Photothermal Spectroscopy*, published in J. Phys. (Paris) **44**, Colloq. C6, Suppl. no. 10 (1983).
- ³M. A. Amer, *Spectroscopie Photoacoustique et Photothermique: Third International Topical Meeting on Photoacoustic and Photothermal Spectroscopy*, published in J. Phys. (Paris) Colloq. **44**, C6-185 (1983).
- ⁴J. Badoz, D. Fourier, and A. C. Boccarra, J. Opt. (Paris) **11**, 399 (1980).
- ⁵J. P. Gordon, R. C. C. Leite, R. S. Moore, S. P. S. Porto, and J. R. Whinnery, J. Appl. Phys. **36**, 3 (1965).
- ⁶C. K. N. Patel and A. C. Tam, Rev. Mod. Phys. **53**, 517 (1981).
- ⁷W. P. Mason and R. N. Thurston, *Physical Acoustics*, Vol. XIV (Academic, New York, 1979).
- ⁸G. C. Wetsel, J. Opt. Soc. Amer. **70**, 471 (1980).
- ⁹M. H. de Paula, A. A. Carvalho, S. Mascarenhas, and R. L. Zimmerman, Med. Phys. **11**, 866 (1984).
- ¹⁰M. H. de Paula, A. A. Carvalho, and M. A. Aegerter, Patent required PI 8403213 (Brazil).
- ¹¹A. Rosencwaig, *Photoacoustics and Photoacoustic Spectroscopy* (Wiley, New York, 1980), p. 242.
- ¹²S. D. Campbell, S. S. Yee, and A. A. Fromowitz, IEEE Trans. Biomed. Eng. **BME-26**, 220 (1979).
- ¹³E. Pines and T. Cunningham, in *Bioengineering and the Skin*, edited by A. Marks and P. A. Payne (MTP, Kluwer Academic, Hingham, MA, 1981), p. 283.
- ¹⁴P. Poulet and J. Chambon, *Spectroscopie Photoacoustique et Photothermique: Third International Topical Meeting on Photoacoustic and Photothermal Spectroscopy*, published in J. Phys. (Paris), Colloq. **44**, C6-413 (1983).
- ¹⁵P. J. Helander, Photoacoust. Spectrosc. **1**, 103 (1982); **1**, 203 (1982); **1**, 251 (1982).
- ¹⁶D. H. McQueen, J. Phys. D **15**, 437 (1982).
- ¹⁷D. H. McQueen, J. Phys. **16**, 738 (1983).
- ¹⁸The LiNbO_3 crystal has been kindly provided by Prof. Dr. J. P. Andreeta of the Crystal Growth Laboratory of our Institute.
- ¹⁹M. H. de Paula and M. A. Aegerter, Anal. Lett. **19**, 231 (1986).
- ²⁰A. Rosencwaig, *Advances in Electronics and Electron Physics*, edited by L. Marton (Academic, New York, 1978), Vol. 46.
- ²¹A. M. Merle, A. Cherqaoui, and L. Brzezinski, *Spectroscopie Photoacoustique et Photothermique: Third International Topical Meeting on Photoacoustic and Photothermal Spectroscopy*, published in J. Phys. (Paris) Colloq. **44**, C6-361 (1983).
- ²²K. Vecranjaneyulu and V. S. R. Das, J. Exp. Botany **33**, 515 (1982).