

# A sol-gel derived AgCl photochromic coating on glass for holographic application

Martin Mennig, Herbert Krug, Claudia Fink-Straube, Peter William Oliveira, Helmut Schmidt

Institut für Neue Materialien, Universitätscampus,  
D-6600 Saarbrücken 11, FRG

## ABSTRACT

A sol-gel derived photochromic glass coating of about 1.5  $\mu\text{m}$  in thickness is synthesized by infiltration of  $\text{Ag}^+$  into a predried Na-Al-B-Si gel layer. The formation of small Ag colloids is initiated by a soft heat treatment and the colloids are converted by a HCl vapour treatment into AgCl crystallites of about 40 nm in diameter. The coating darkens by UV irradiation, forming Ag crystallites of about 5 nm in size. This process is completely reversible at 400 °C and no decay is observed in numerous cycles. An amplitude hologram which acts as a diffraction grating with a grating period of about 10  $\mu\text{m}$  can be produced within this layer by a two-wave mixing experiment with laser light of 351 nm wavelength. The diffraction efficiency of this grating is determined to 0.11 %. After thermal erasing the diffraction pattern can be rewritten and erased repeatedly without any loss of efficiency.

## 1. INTRODUCTION

The sol-gel process is a low temperature route, enabling the synthesis of glasses and ceramics, new glass compositions and special products such as fibers, foils, monoliths, composites and coatings<sup>1,2</sup>. The preparation of photochromic sol-gel glasses is of particular interest. As recently shown, it is possible to prepare a sodium aluminoborosilicate glass powder containing  $\text{AgCl}_x\text{Br}_{1-x}$  nanosized crystallites by the sol-gel route<sup>3,4</sup> as well as sol-gel-coatings on glass in the same system doped with AgCl particles<sup>5</sup>. Both materials show a photochromic behaviour. They darken after UV irradiation and - as expected - recovery has to be activated thermally. The coatings can be bleached and darkened without loss of efficiency and are highly transparent. Based on these properties, it was of interest to write holographic patterns into such layers.

## 2. EXPERIMENTAL

The preparation of the coatings and processing to photochromic layers is described elsewhere<sup>5</sup>. In fig. 1 a flow diagram of the processing is shown.

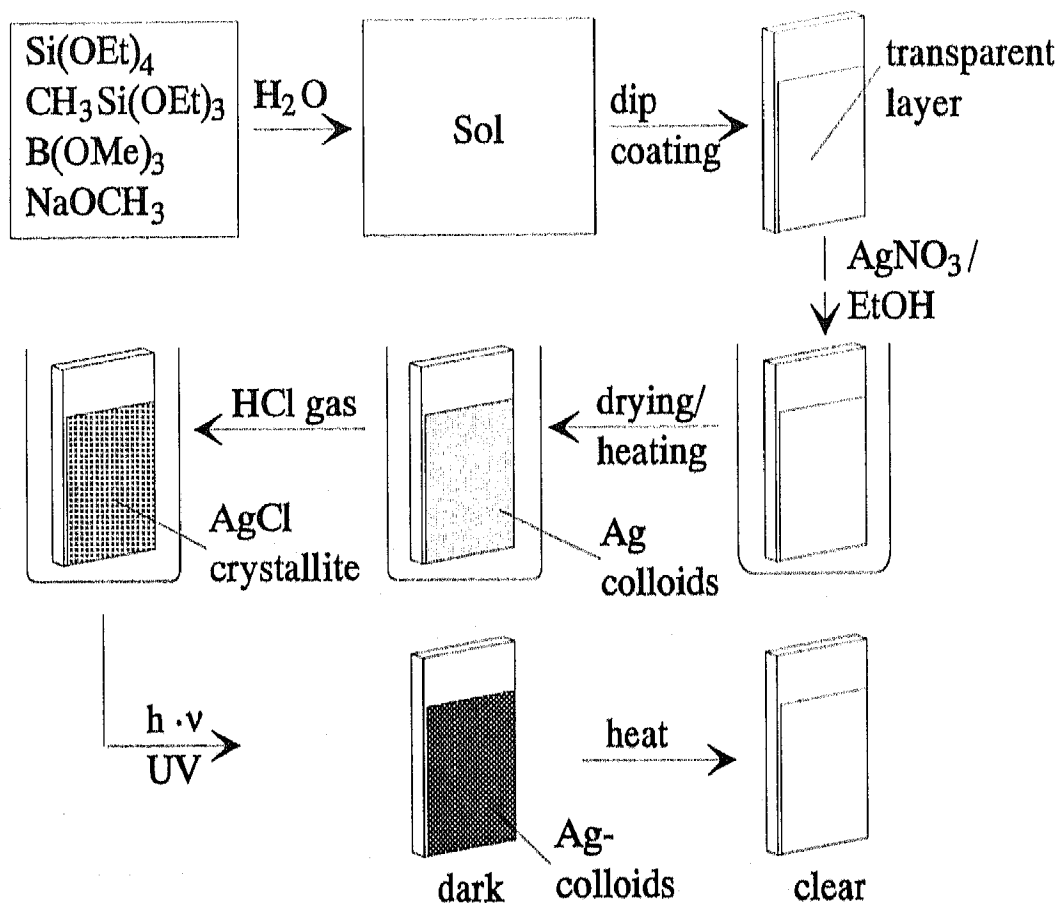

Fig.1: Processing of photochromic  $\text{Na}_2\text{O} \cdot \text{BO}_2 \cdot \text{SiO}_2$  layers

The sol for a glass with a composition of 59.5 mole-%  $\text{SiO}_2$ , 20.5 mole-%  $\text{B}_2\text{O}_3$ , 9.5 mole-%  $\text{Al}_2\text{O}_3$  and 10.5 mole-%  $\text{Na}_2\text{O}$  (a typical composition of a photochromic glass made from a melt<sup>6</sup>) was synthesized using tetraethyl orthosilicate, methyltriethoxysilane, trimethyl borate alumina isopropoxide as precursors. Ethylene glycole and hydroxypropyl cellulose<sup>7</sup> were added as drying control chemical additives (DCCA). With this sol soda lime microscopy slides were coated via a dipping procedure yielding to  $1.5 \mu\text{m}$  thick layers after drying. After infiltration in silver nitrate solution, silver chloride was formed by exposure of the films to a hydrochloric acid vapour. The coatings were irradiated with a 700 W high-pressure-mercury-xenon-lamp at a distance of about 30 cm and thermally bleached at temperatures between 100 and 400 °C. The photochromic properties were investigated using UV/VIS spectroscopy.

An amplitude hologram was generated in the coatings with a two-wave mixing experiment as shown in fig. 2.

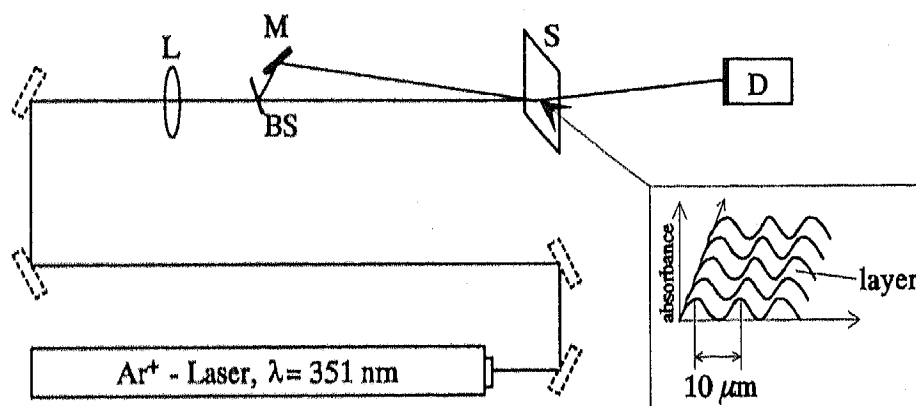

Fig. 2: Two-wave mixing experiment

A laser beam of 351 nm in wavelength (from an  $\text{Ar}^+$ -laser) is splitted into two beams of the same power by a beam splitter (BS) and a directional mirror (M). These two writing beams interact at an angle of  $2^\circ$  and interference leads to a periodic illumination of the sample producing a spatial modulation of the intensity dependent colouration. The distance between the beam splitter and the directional mirror is about 3 cm, which is much more less than the coherence length of the laser radiation. The energy density in the interference region is spatially modulated with a period of  $10 \mu\text{m}$  as schematically indicated in fig. 2. The interference region has  $600 \mu\text{m}$  in diameter and the incident power density is  $7.3 \text{ W/cm}^2$ .

If a local variation of the absorption coefficient occurs in a periodic pattern, a diffraction grating is built and the diffraction pattern can be visualised due to self-diffraction of the writing beams. The intensity of the first order of the diffraction pattern is monitored by a photodiode (D) in dependence of the illumination time. The diffraction efficiency  $\epsilon$  can be determined with equation (1) from the measured intensity  $I$  of the first diffraction order divided by the intensity of the incident beam  $I_0$ .

$$\epsilon = I / I_0 \quad (1)$$

To erase the laser written hologram, the sample was thermally treated at 400 °C for 1 hour.

### 3. RESULTS AND DISCUSSION

The coating irradiated with the high-pressure-mercury-xenon-lamp turned brown-violet. Fig. 3 shows the increase of the absorbance of the coating as a function of the irradiation time for two characteristic wavelengths.

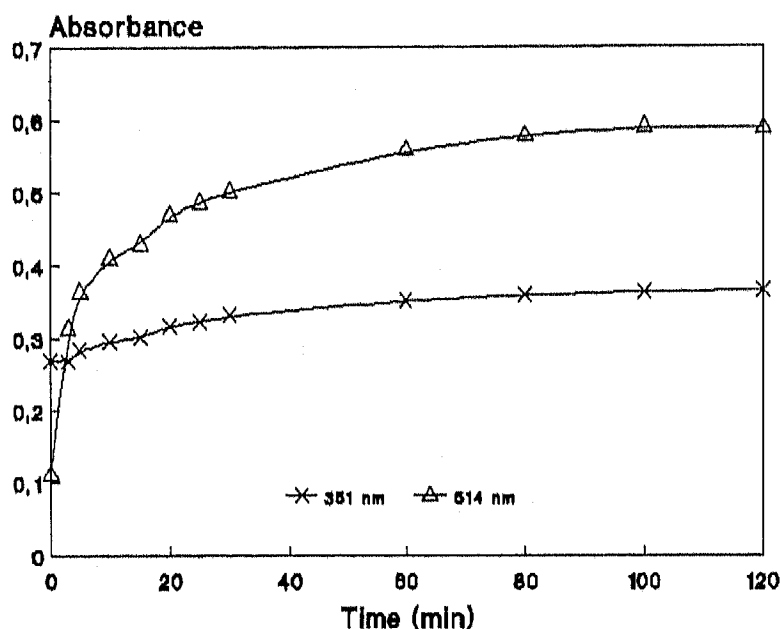

Fig. 3: Darkening of the photochromic layer as a function of illumination time for 351 nm and for 514 nm wavelength

The upper plot is taken for 514 nm wavelength, the maximum position of the photoinitiated absorbance in the UV VIS spectrum. The second curve shows the increase in the absorbance at 351 nm wavelength of the Ar<sup>+</sup>-laser. Both curves show a time dependent increase of the absorption reaching a saturation level after about 1 hour. Fig. 4 shows the bleaching behaviour of the coating.

The absorbance for 351 nm and 514 nm wavelength respectively decreases after a cumulating heat treatment at 100 °C, 2 °C, 300 °C and 400 °C for 1 hour. Cumulating means that the

absorbance at f. i. 300 °C was measured after the coating was heat treated 1 h at 100 °C, 1 h at 200 °C and additionally 1 h at 300 °C. For both curves one can see that the absorbance only slightly decreases for

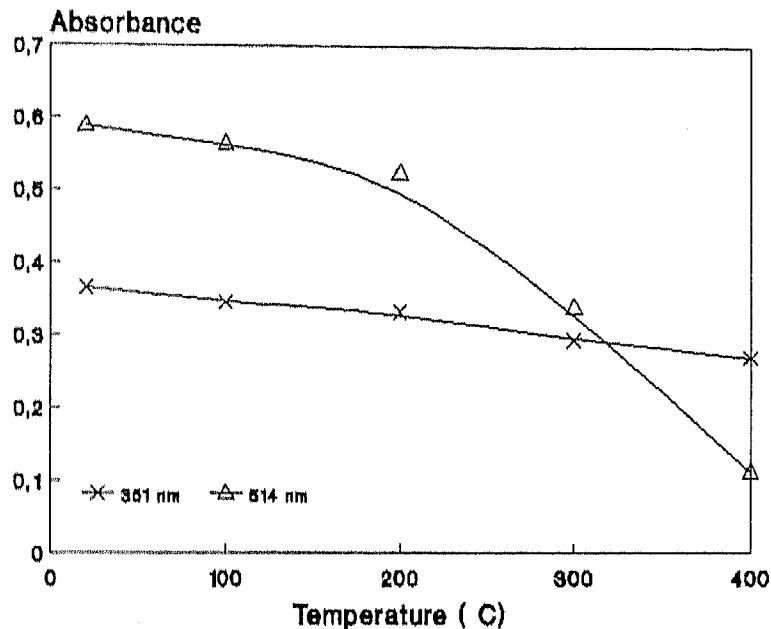

Fig.4: Thermally activated bleaching of a darkened coating (until saturation) as a function of the temperature

temperatures up to 200 °C. A comparison between the absorbance values of 400 °C (0.1 for 514 nm and 0.28 for 351 nm) with the starting values of the darkening experiment in fig. 3 leads to the result, that the colouring effect is completely recovered by the thermal treatment.

Previous investigations<sup>5</sup> with X-ray diffraction and electron microscopy had clearly shown, that this photochromic behaviour is attributed to the reversible formation of Ag colloids of about 5 nm in size from AgCl particles of about 40 nm.

The result of the two-wave mixing experiment is illustrated in fig. 5. The local formation of crystalline silver<sup>5</sup> is directly correlated to the absorption coefficient of the material. In case of a spatial modulation of the darkening, an amplitude hologram is formed with change of the diffraction efficiency in dependence on the illumination time.

One can see, that the efficiency is increasing with exposure time, reaching a maximum of about 0.10 % after 18 min. After that it is slightly decreased to about 0.08 %. This can be attributed to scattering effects from dust on the optical set up resulting in spacial randomly distributed hot-spots and from grain

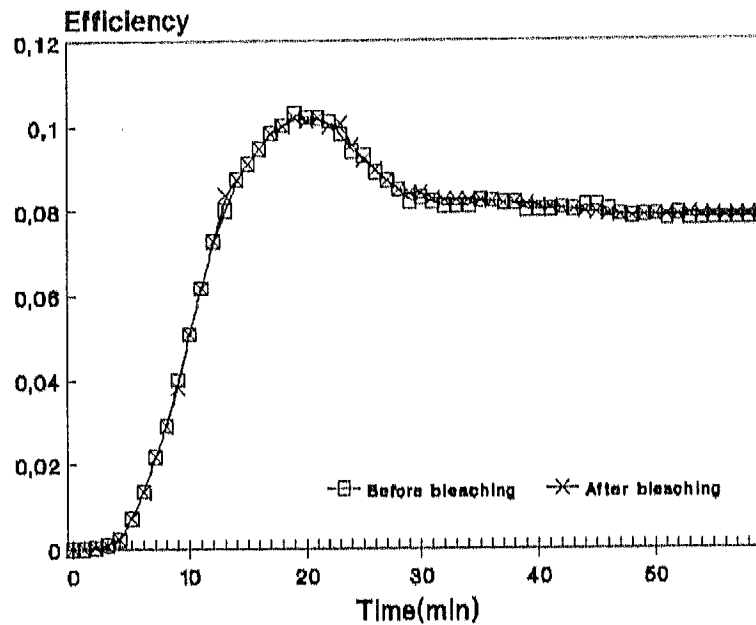

Fig. 5: Diffraction efficiency measurement during a two wave mixing experiment ( $\text{Ar}^+$ -laser with 351 nm wavelength) for a thermally untreated and a thermally bleached layer

scattering in the photochromic layer caused by the relatively large AgCl crystallites. Regions of the photochromic layer with minimal intensity of the laser interference pattern are additionally darkened by this scattered light and this leads to a smearing of the absorption profile. For the measurement in fig. 5 laser power of 20 mW of each beam was used. For a lower laser power of 5 mW the time for establishing the holographic pattern is increased to more than 1 h. The diffraction efficiency could not be measured for this hologram because the intensity of the first order was too low in comparison to the sensitivity of the used photodiode. For higher laser powers it may be assumed that building up of a hologram can be done faster than shown in fig. 5. An optimization of the writing kinetics should be able either by increase of the laser power or by improving the darkening kinetics of the layer, for instance by generation of smaller sized AgCl particles or by sensitizing it with  $\text{Cu}^+$  ions.

Fig. 5 also clearly shows that the diffraction efficiency of the holographic grating follows the same time dependence before and after the thermal bleaching process.

A theoretical estimation of the diffraction efficiency of the first order can be calculated with equation (2)<sup>9</sup>

$$\epsilon = (\Delta n \cdot d / \lambda_c)^2 + (\Delta k \cdot d)^2 / 4 \quad (2)$$

where  $\Delta n$  is the difference of the refractive index and  $\Delta k$  is the difference of the optical density of the absorbing and not absorbing regions of the written grating and  $\lambda_c$  is the wavelength. The approximation (2) is only valid for small  $\Delta k$ <sup>9</sup>. Assuming that  $\Delta n \approx 0$  one can very roughly estimate an efficiency of about 0.09 % using the values of the optical density in the darkened and bleached state of the photochromic layer from UV VIS absorbance measurements (compare fig. 3) at 351 nm wavelength ( $\Delta k \approx 0.12$ ). This is in good agreement with the measured efficiency of 0.10 % (after 18 minutes). Thus it can be assumed that a higher efficiency may be obtained for visible light, where higher  $\Delta k \cdot d$  values can be realised (compare fig. 3). It can be seen clearly, that the difference in the absorbance between the irradiated and the unirradiated state is much higher for 514 nm than for 351 nm. Therefore it can be expected that a holographic grating should have a higher diffraction efficiency for a 514 nm wavelength than for the wavelength used for the holographic experiment. This was proved by using a laser beam with 514 nm wavelength for the measurement of the diffraction efficiency of a grating written with 351 nm wavelength. A diffraction efficiency of 0.34 % was realised, which is a promising value for future optimization of the system.

#### 4. CONCLUSIONS

The application of the sol-gel technique enables the synthesis of a photochromic coating on glass, where the photochromic effect is based on silver chloride particles. The holographic experiments have clearly shown that this layer in principle can be used as an optical storage material for write-and eraseable holograms with a good diffraction efficiency that should be still much better in a layer with optimized optical properties. The next interesting questions are, which optical resolution can be obtained by the writing process and whether the erasing process can be carried out locally by IR-laser light instead of the thermal bleaching in a furnace. Future experiments will focus on the optimization of the process parameters for the development of systems with predetermined photothermal behaviour.

#### 5. REFERENCES

1. H. Dislich, "Glassy and crystalline systems from gels: chemical basis and technical application", J. Non-Cryst. Sol. Vol. 57, p. 371-388, 1983.
2. J. P. Mackenzie, "Glasses from melts and glasses from gels, a comparison", J. Non-Cryst. Sol. Vol. 48, p. 1-10, 1982.
3. M. Mennig, H. Schmidt, C. Fink, "Synthesis and properties of sol-gel derived  $\text{AgCl}_x\text{Br}_{1-x}$  colloid containing sodium aluminoborosilicate glasses", SPIE Vol. 1590, 152-159, SPIE Bellingham, Washington, 1991.
4. H. Schmidt, M. Mennig, C. Fink, "Photochrome Gläser, Verfahren zu ihrer Herstellung und ihre Verwendung", Deutsches Patent, DP 41 29 409.2, (4.9.1991).

5. M. Mennig, C. Fink, H. Schmidt, "A sol-gel derived AgCl photochromic coating on glasses", in: Proc. ICG Congress on Glass, Madrid, 04.-09.Oktober 1992, accepted for publication.
6. B. Yin, "The size of silver halide crystallites precipitated in photochromic glasses", J. Non-Cryst. Sol. Vol. 52, p. 567-572, 1982.
7. Y. Yamamoto, K. Kamiya, S. Sakka, "Study on the properties of coating films prepared from metal oxides", Yogyo-Kyokai-Shi Vol. 90, p. 328-333, 1982.
8. Y. Moriya, "Effects of crystal size, crystal composition and irradiation conditions on the UV-induced absorption spectra in the photochromic glasses", Yogyo-Kyokai-Shi Vol. 83, p. 75-80, 1975.
9. H. J. Eichler, G. Günter, D. W. Pohl, "Laser-Induced Dynamic gratings", Springer Series in Optical Sciences, chapter 4, p. 94-122, Springer-Verlag Berlin-Heidelberg, 1976.